

First, Using the A-Fold technique first used by Flite Test, assemble the Center Pod, then glue on all of the formers using the corresponding marks on the Center Pod.

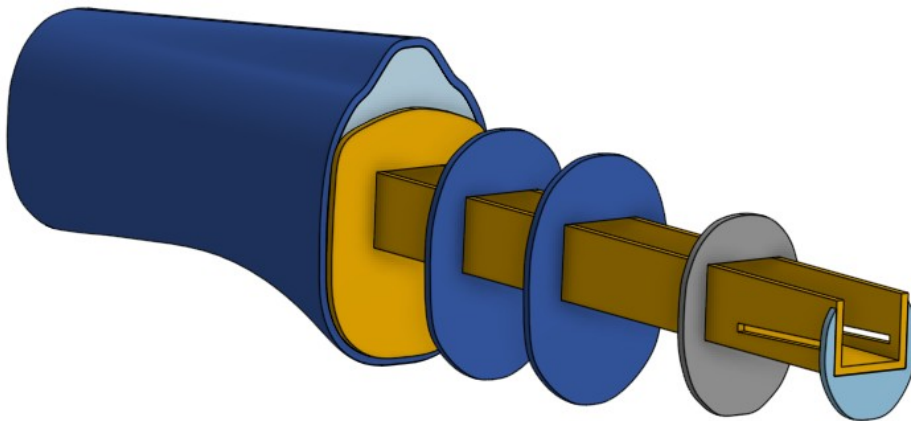

Now Peel the Paper off the Back side of Skin 6 and Form it in the Master Series style brought about by John Overstreet. Now Glue it On as Shown.

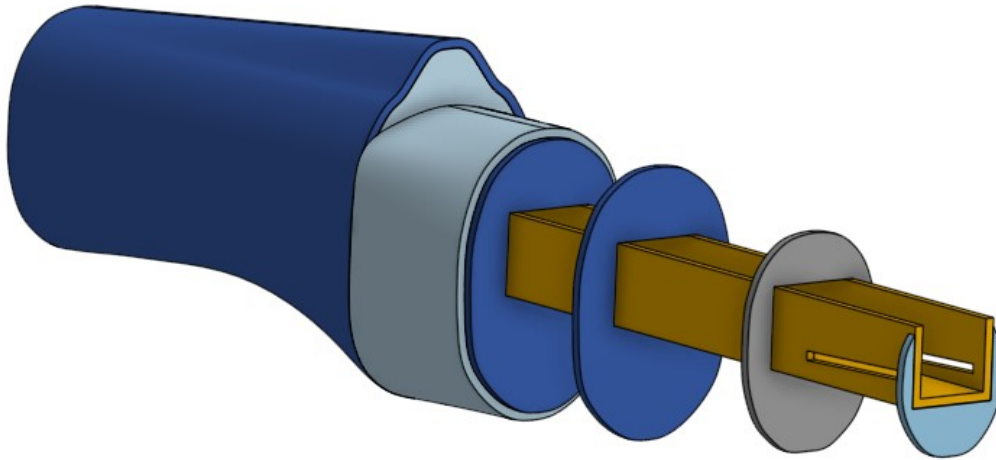

Using the same technique, peel the paper and form skin 5 and glue it on, don't be worried if it carries past the former, as it will all shift correspondingly with the rest of the plane.

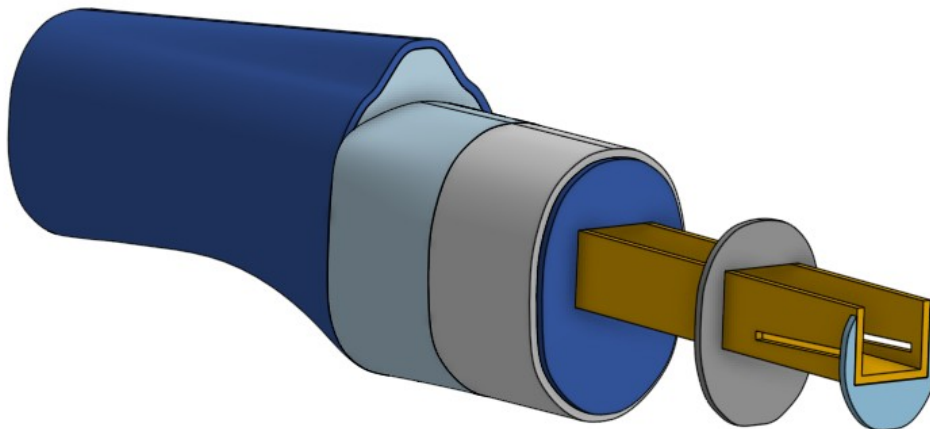

Proceed to do the same exact thing with Skin 4.

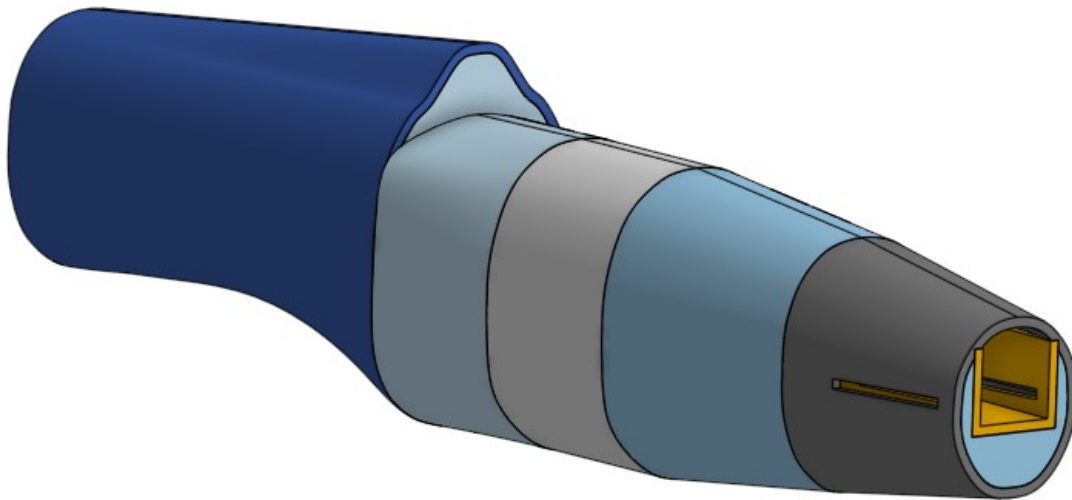
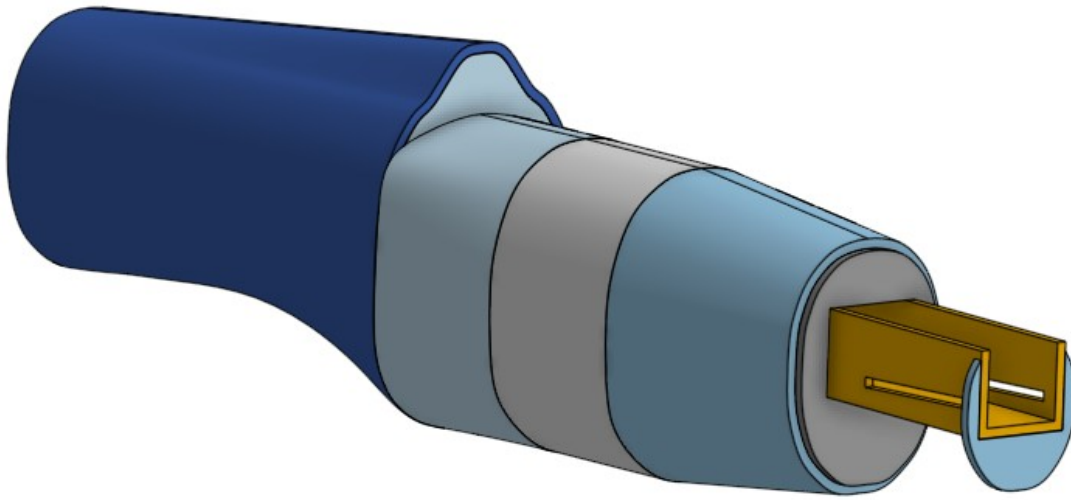

Now do the same thing with Skin 2

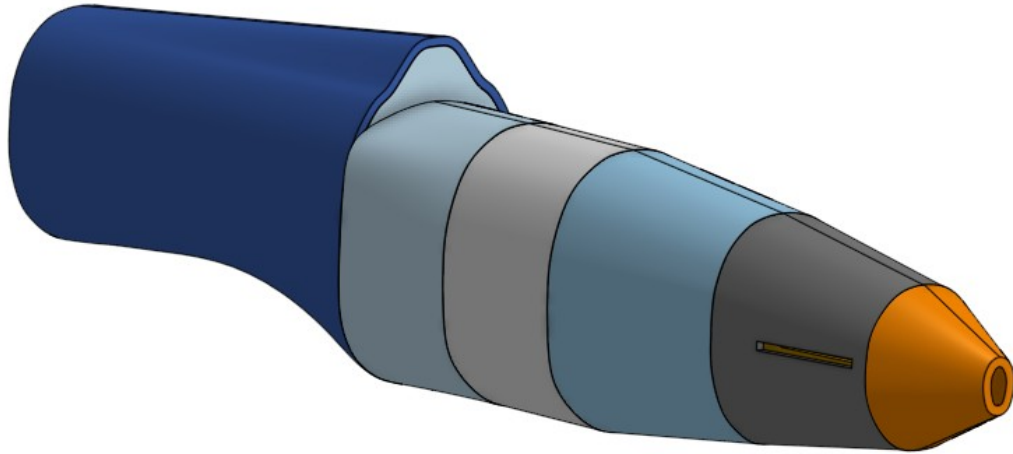

The Nose Skin is a bit different because it will be open at the end with no former or skin to fill the hole, a 3d printed nose will be added later on. If you don't have a 3d printer or have no access to one, you can simply sand a piece of pink insulation foam to shape.

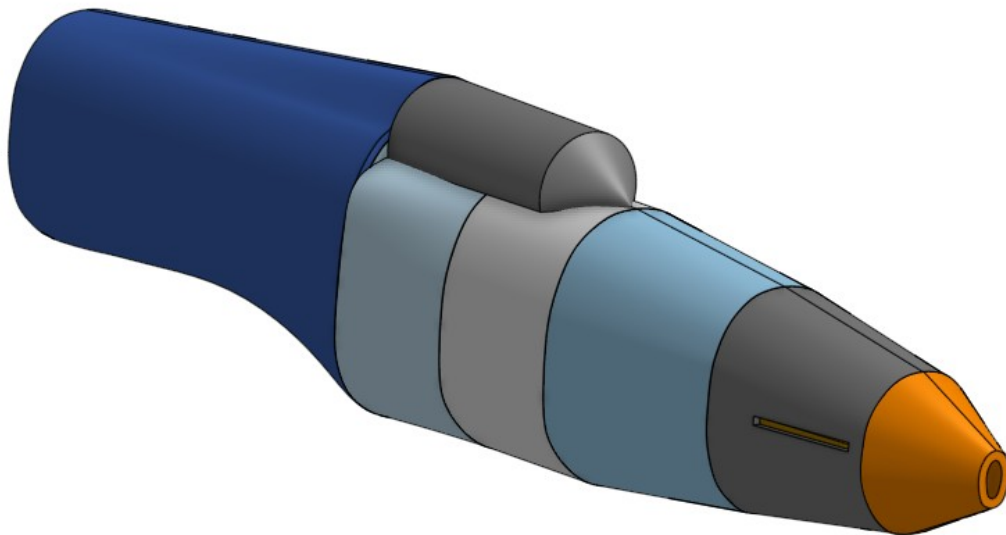

Now Install the Canopy, by first peeling the paper, then forming it against the edge of a table, now glue the front triangle section to the rectangular back rectangular section to complete the canopy. Glue it on.

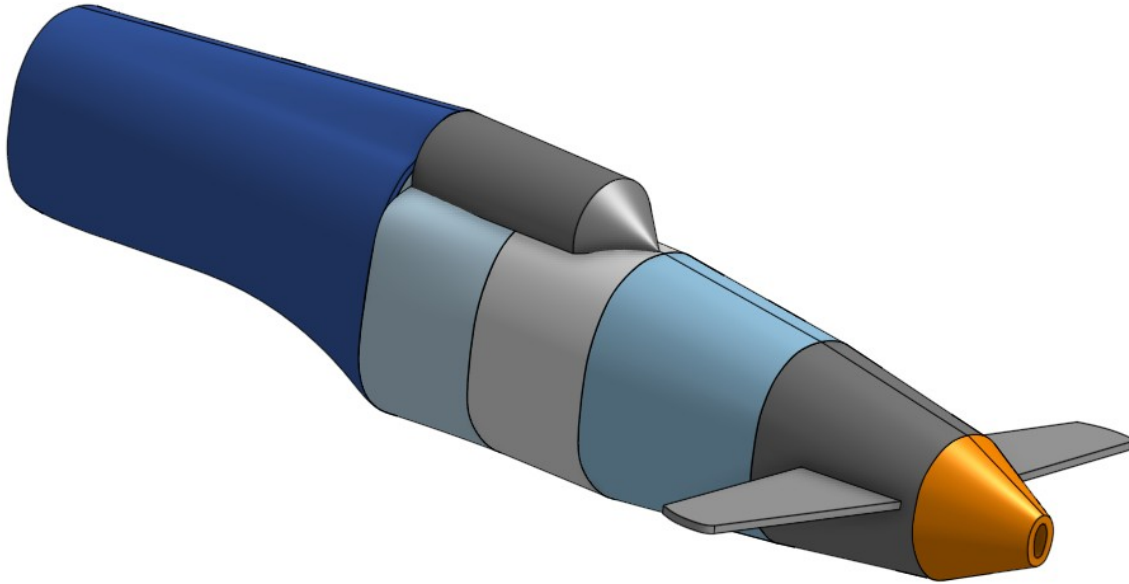

Pass the Canard through the opening in the skin and center pod, trim with a knife if needed. Glue it on the edges.

The wing is done in tradition Flite Test Fassion, except that you bevel the trailing edges. Dihedral is set by 48mm tall object, in other words a roll of packing tape. Also Glue on the Vertical Stabilizers according to the reference lines on the wing. Install wing fillets and you're just about done! Just cut in a battery hatch and install the rest of the electronics.

Happy Flying!