

BluCub2

By
Gene Bond

Motor: EPS-350C-C
Prop: 9x4.7 or 9x7
Battery: 2 cell 800-1500 LiPo
Weight: 9-11 oz
Wing Area ~240 sqin
Wing Loading: 5.5-6.75 oz/sf

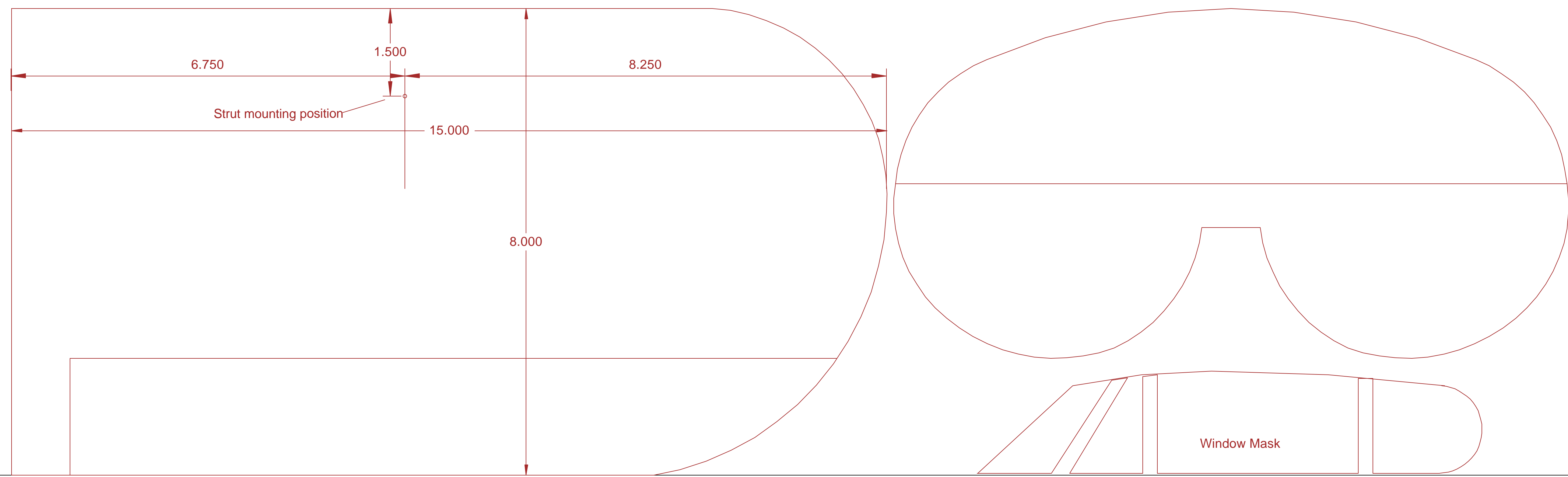

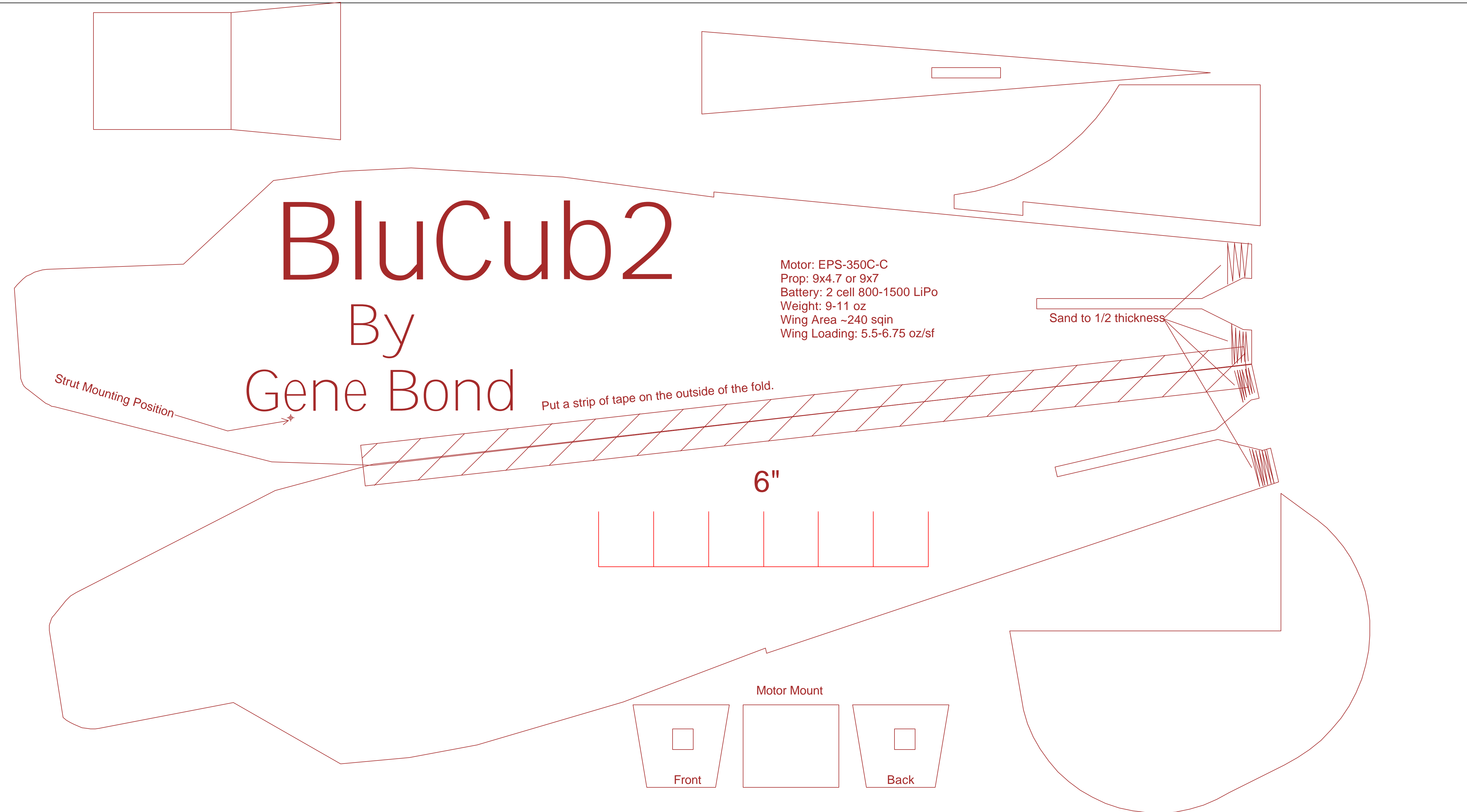
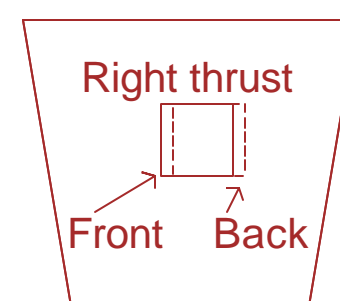
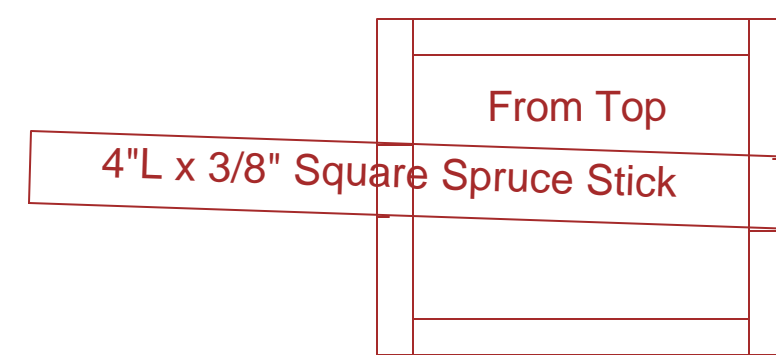
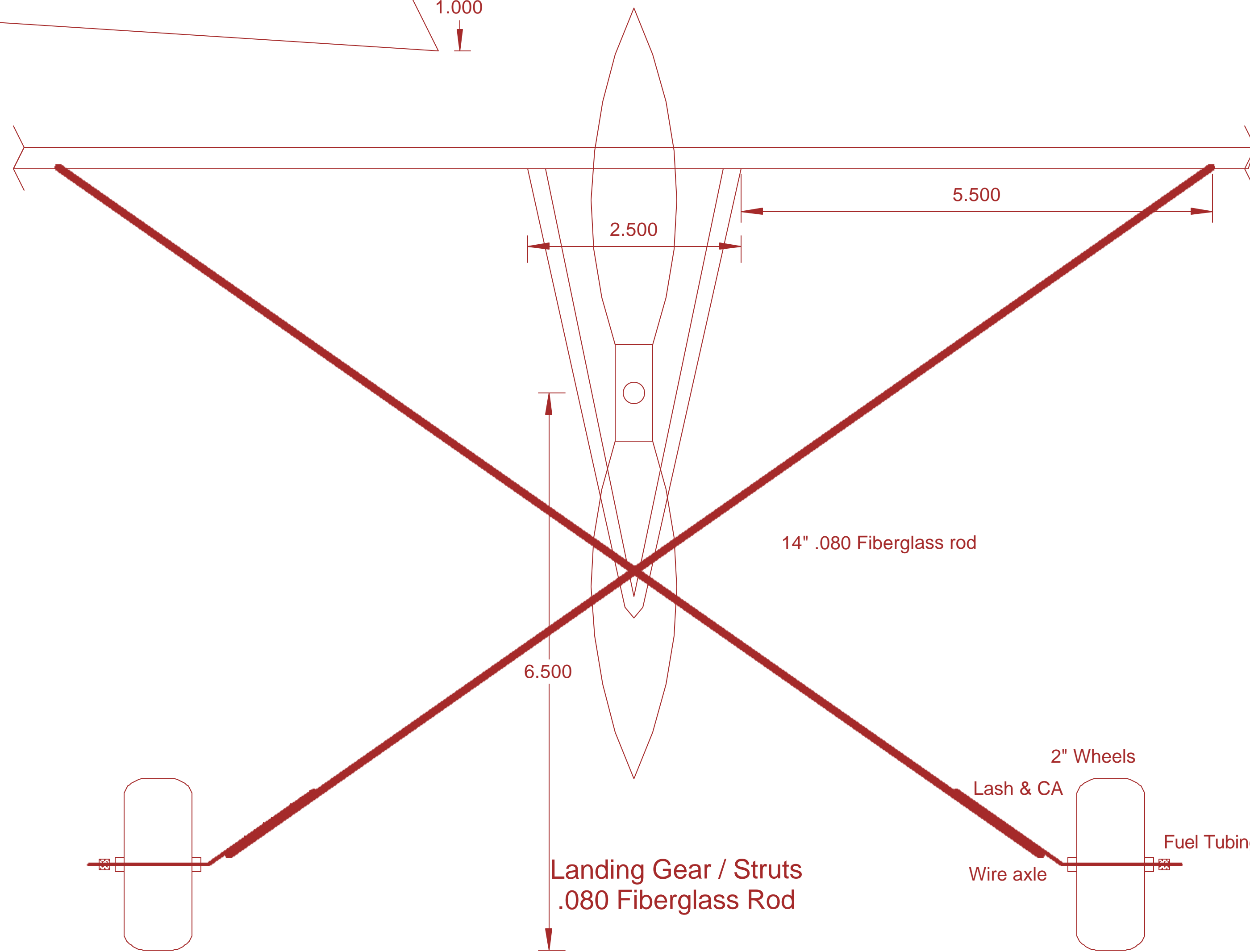
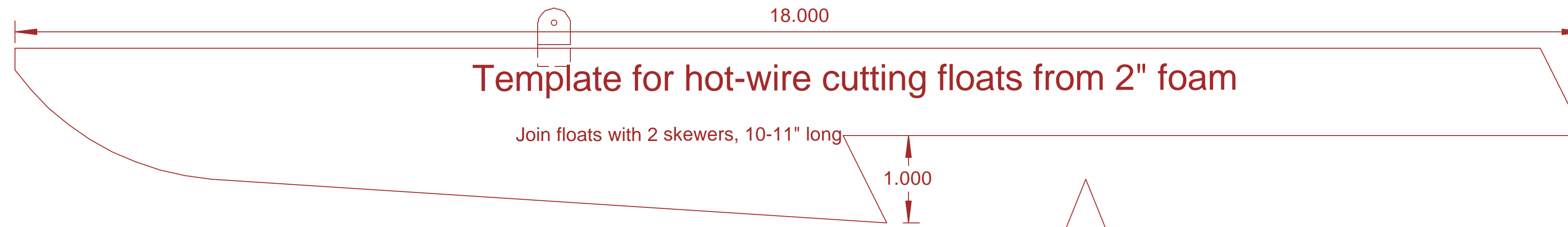
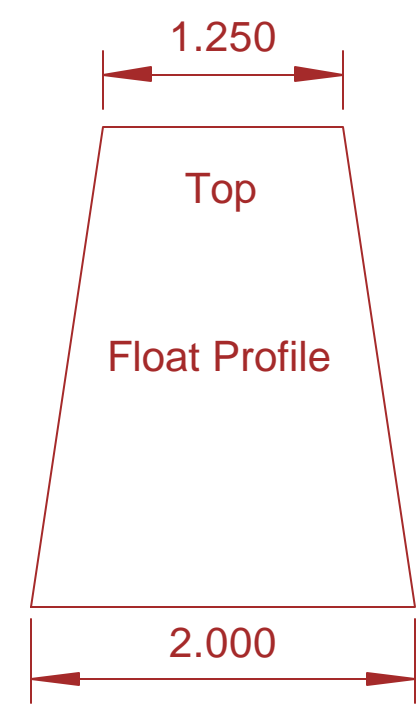

Down thrust set by tracing top line of cowl and lining up top of motor mount with line.

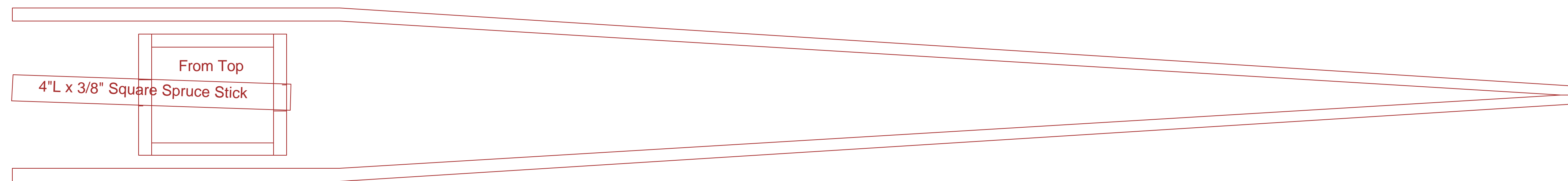
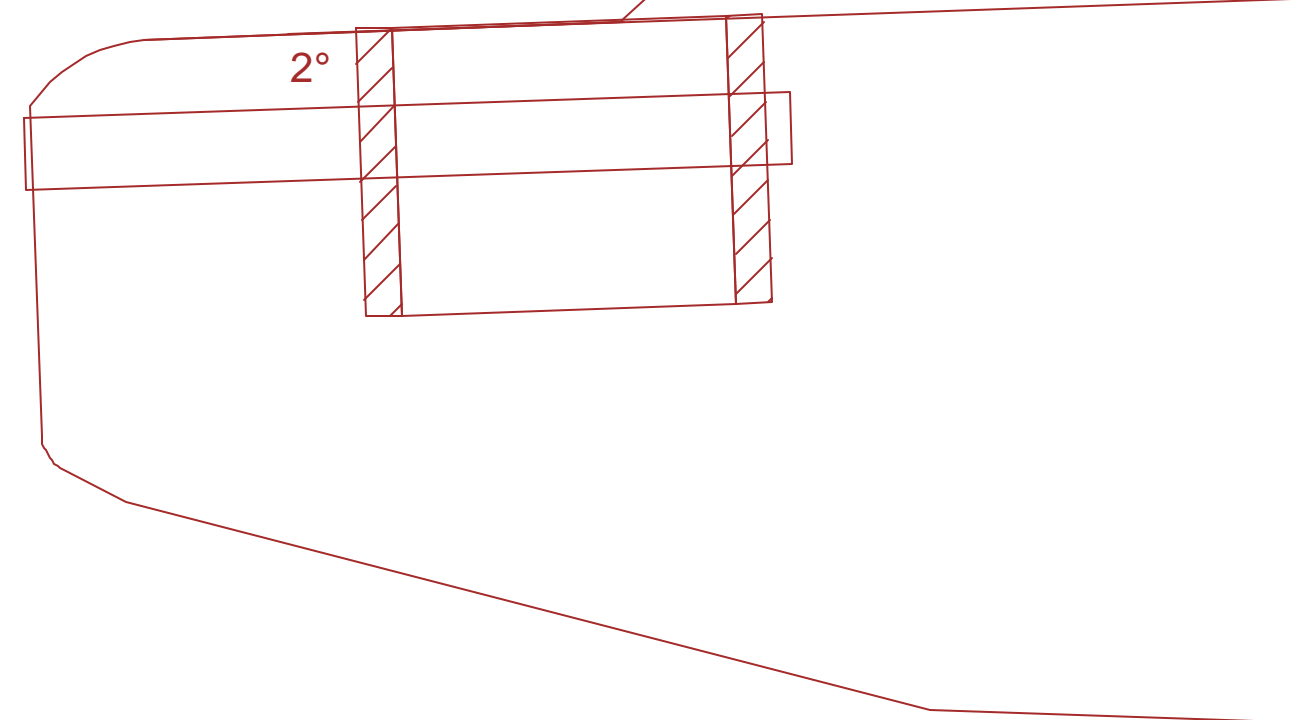

BluCub2

By Gene Bond

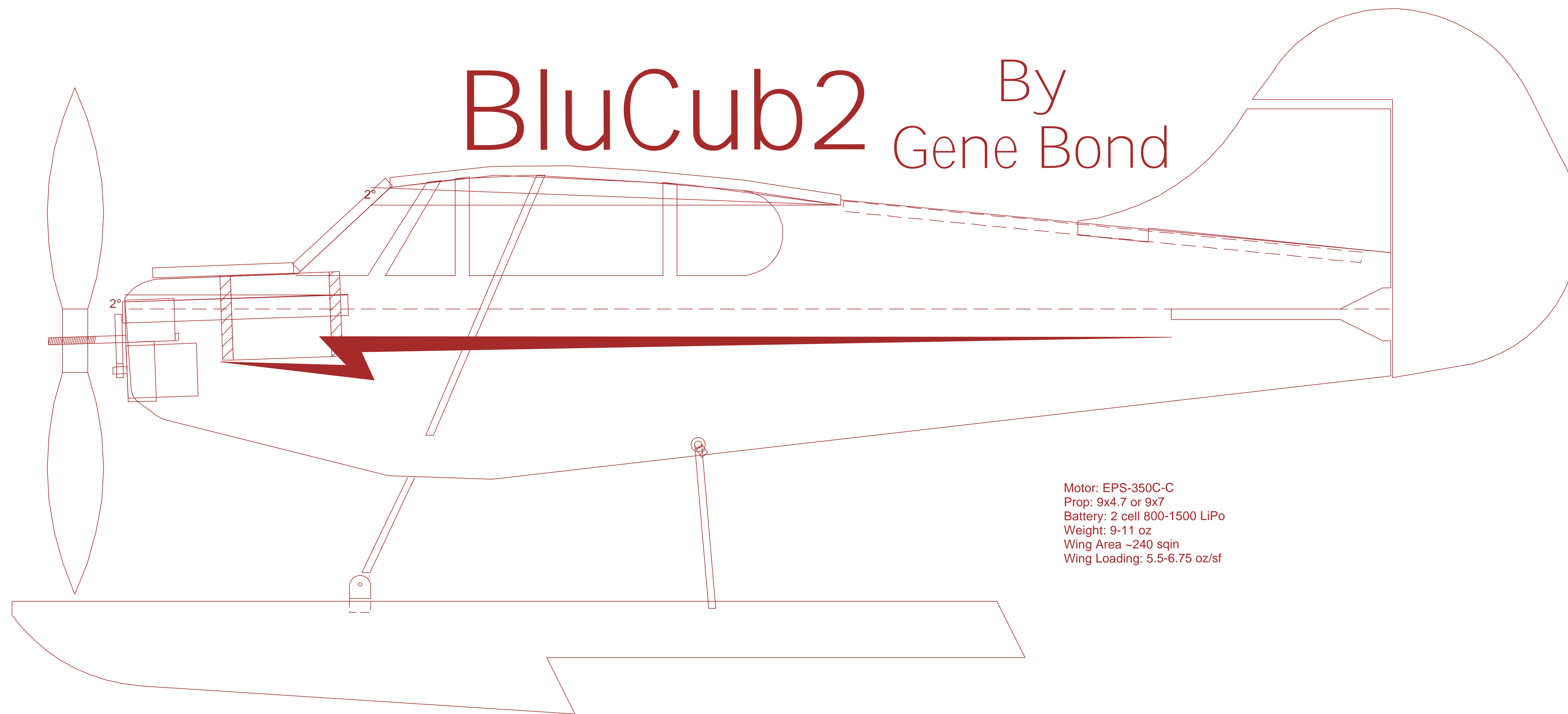

Motor: EPS-350C-C
Prop: 9x4.7 or 9x7
Battery: 2 cell 800-1500 LiPo
Weight: 9-11 oz
Wing Area ~240 sqin
Wing Loading: 5.5-6.75 oz/sf