

8 | 7 | 6 | 5 | 4 | 3 | 2 | 1

P-38/61 Black Lightning Patterns
 Designer-Carlos A Rodriguez

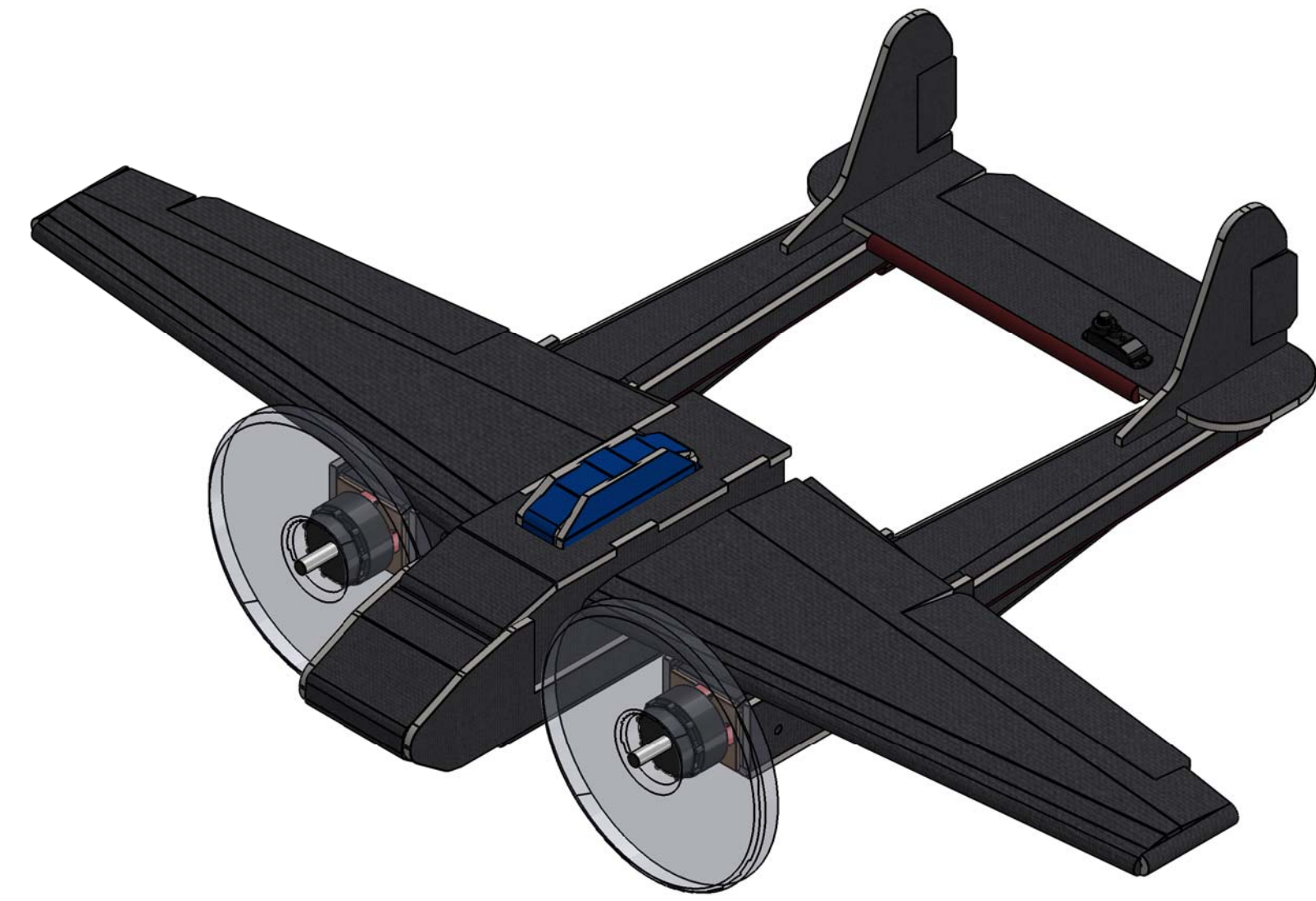
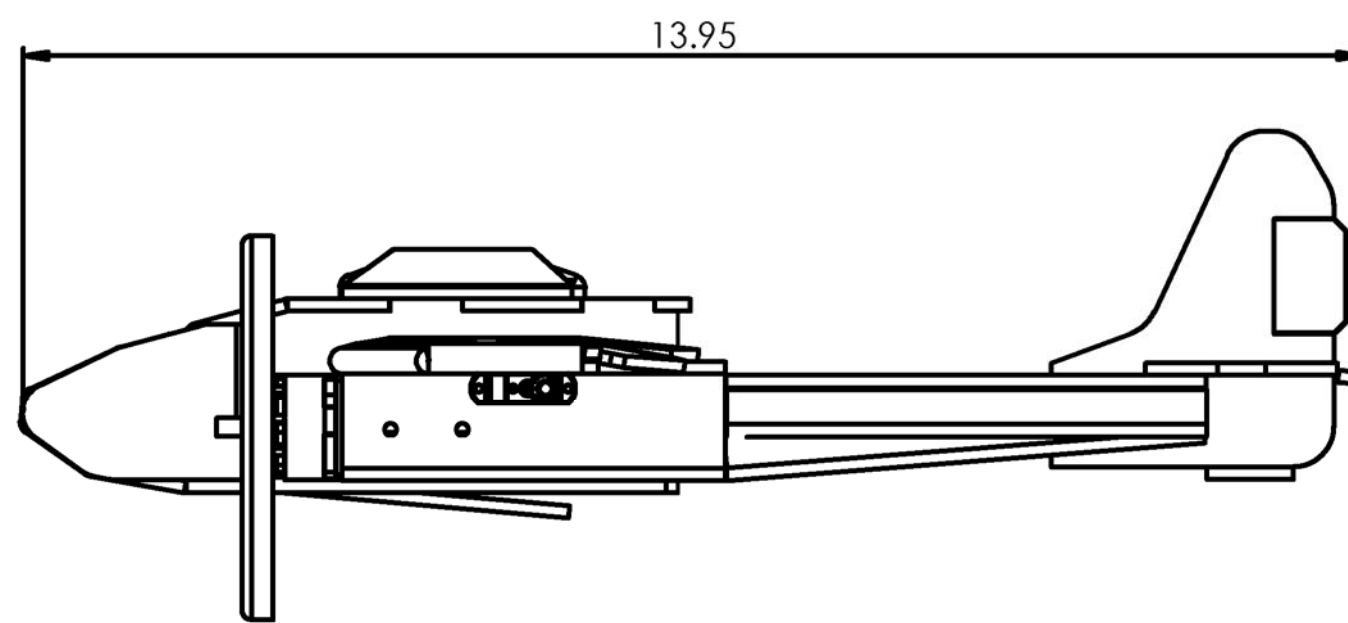
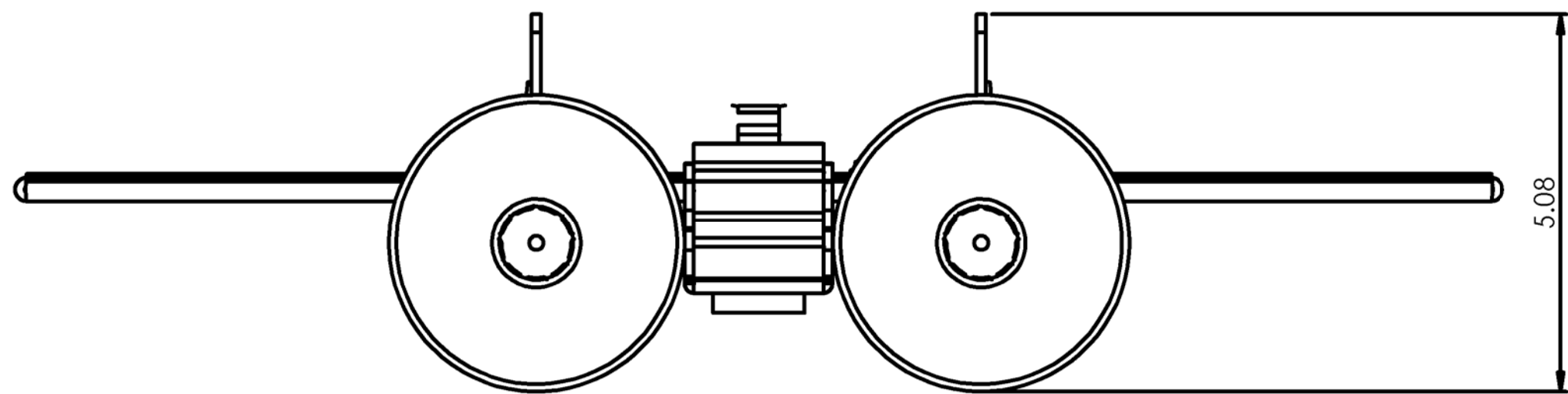
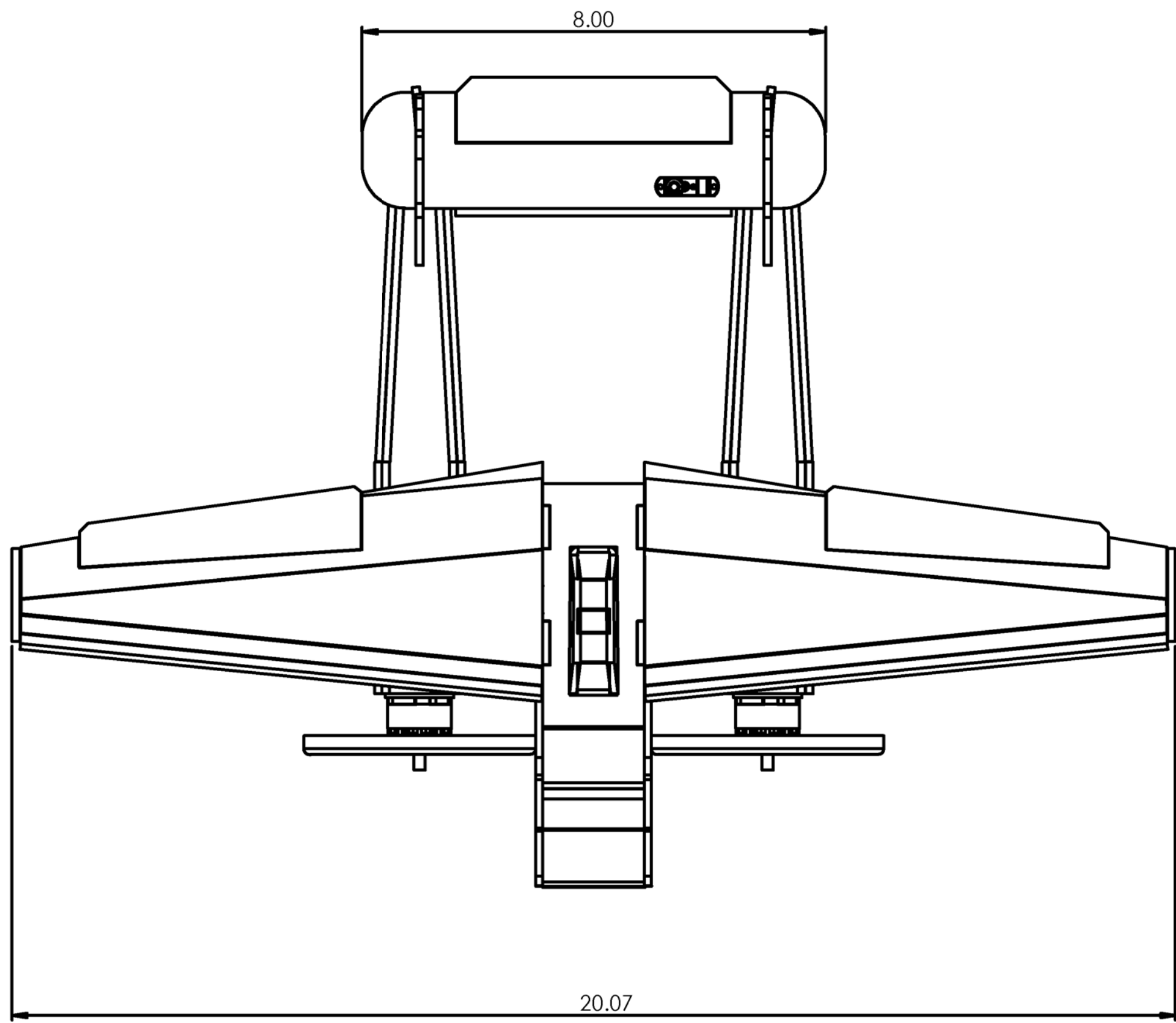

NOTE: I have not yet manually indicated the A or B folds nor the edges that need to be cut. The dotted lines are the "bend" centers, NOT the edges to cut or slice. You will have to reverse engineer the bends until I have the time to add them myself. The pattern may also run a little long at times as the program doesn't easily account for length needed to bend foamboard so hopefully I corrected it. 180 degree folds are C-Type and the wing edge can be whatever fits your fancy right now.
 GOOD LUCK and thanks for checking this bird out.

UNLESS OTHERWISE SPECIFIED: DIMENSIONS ARE IN INCHES TOLERANCES: FRACTIONAL: ± 1/16" ANGULAR: MATCH TWO PLACE DECIMAL: ± 0.01" THREE PLACE DECIMAL: ± 0.005"		DRAWN: _____ CHECKED: _____ DESIGNED: _____ DATE: _____	NAME: _____ DATE: _____
PROPRIETARY AND CONFIDENTIAL THE INFORMATION CONTAINED IN THIS DRAWING IS THE SOLE PROPERTY OF _____ REPRODUCTION IN PART OR AS A WHOLE WITHOUT THE WRITTEN PERMISSION OF _____ IS PROHIBITED.		COMMENTS: _____ _____	TITLE: _____
MATERIAL: _____ NEXT ASSY: _____ USED ON: _____ APPLICATION: _____	FINISH: _____ DO NOT SCALE DRAWING	SCALE: 1:1 WEIGHT: _____	SIZE: D FT Mini P-38 REV: _____ SHEET 1 OF 3

8 | 7 | 6 | 5 | 4 | 3 | 2 | 1

P-38/61 Black Lightning Patterns
Designer-Carlos A Rodriguez

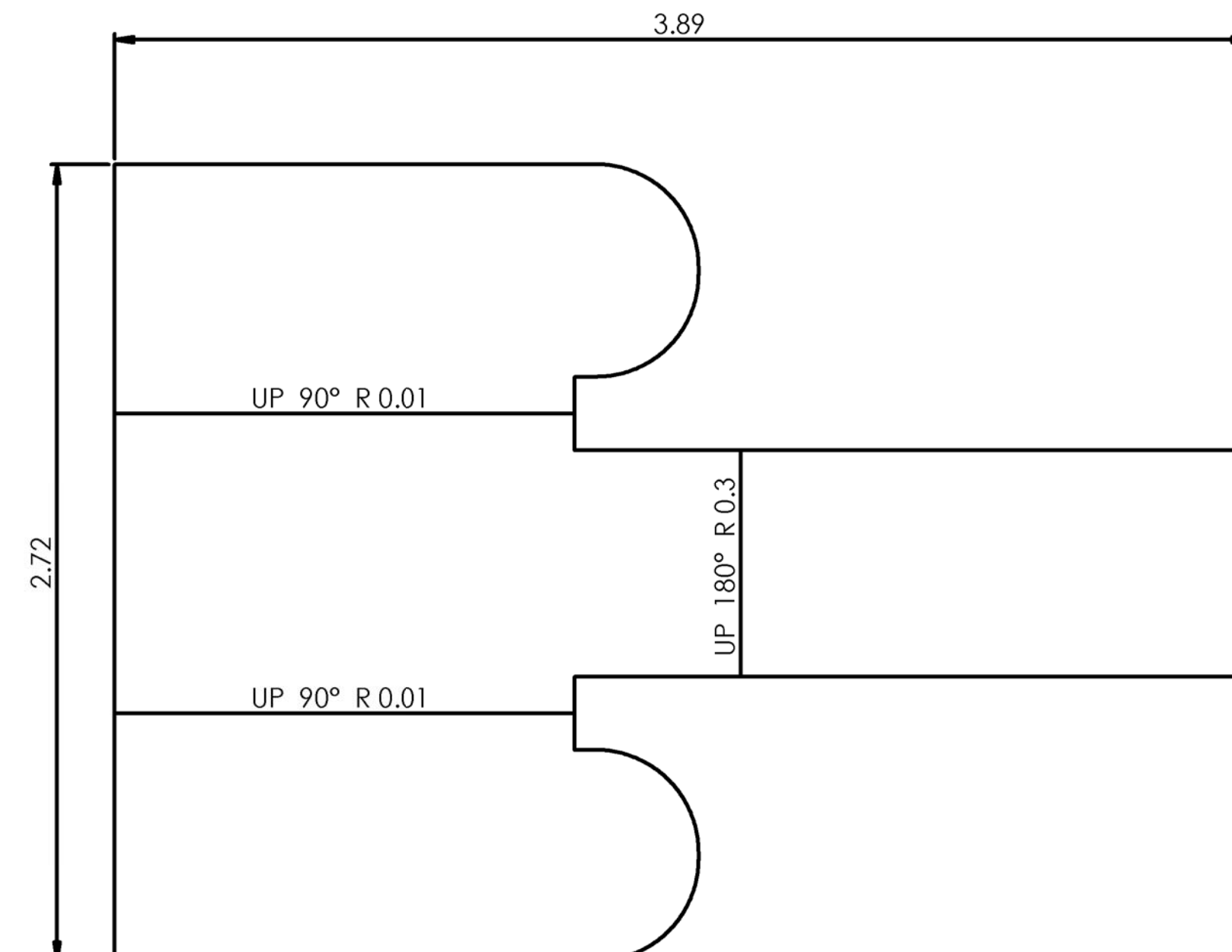
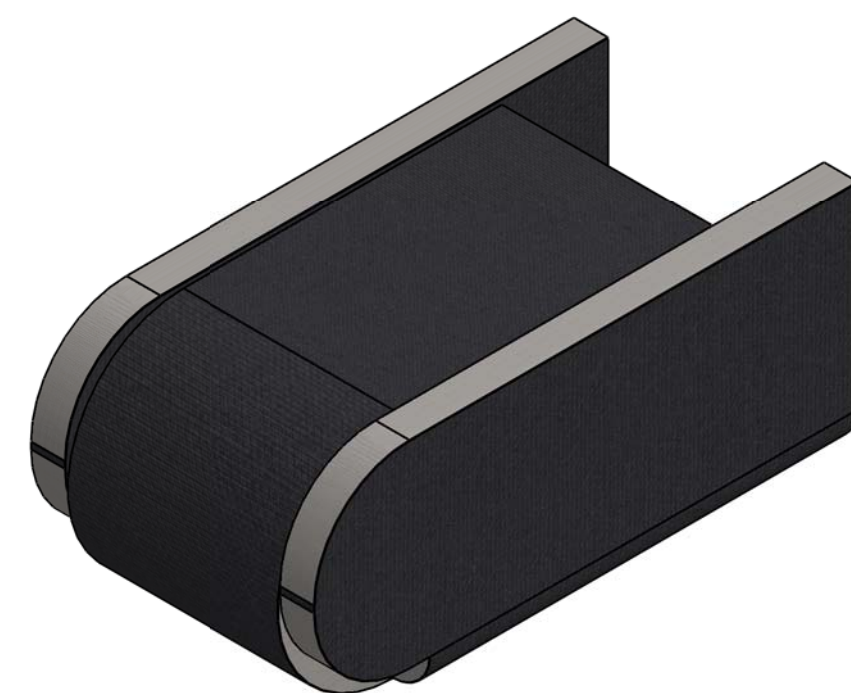
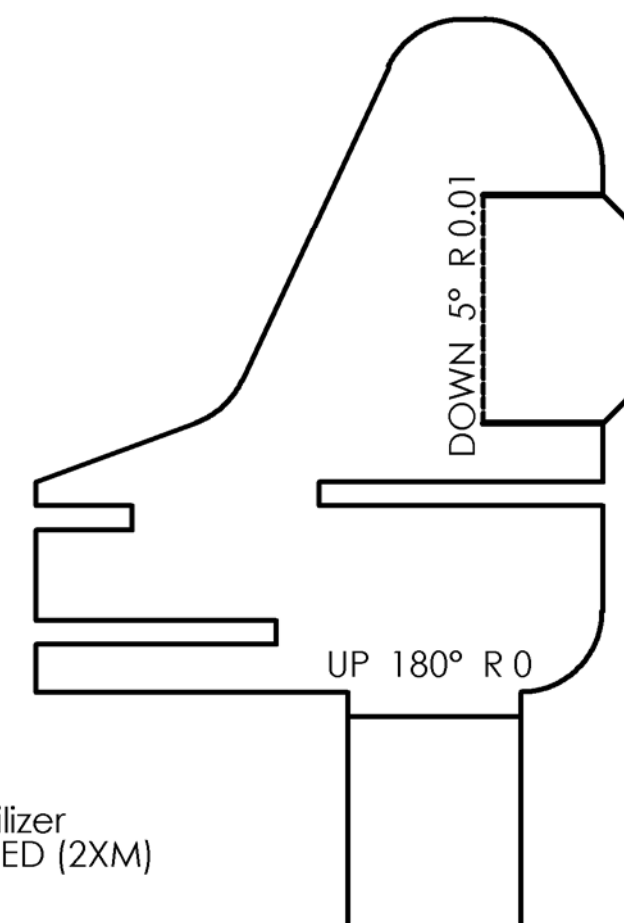
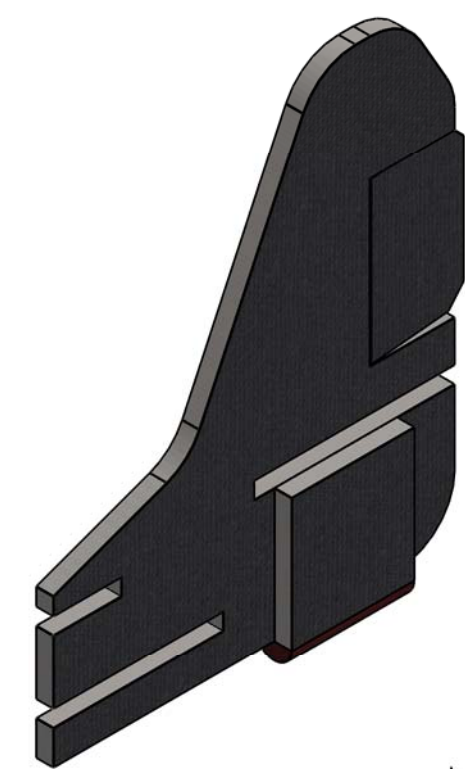
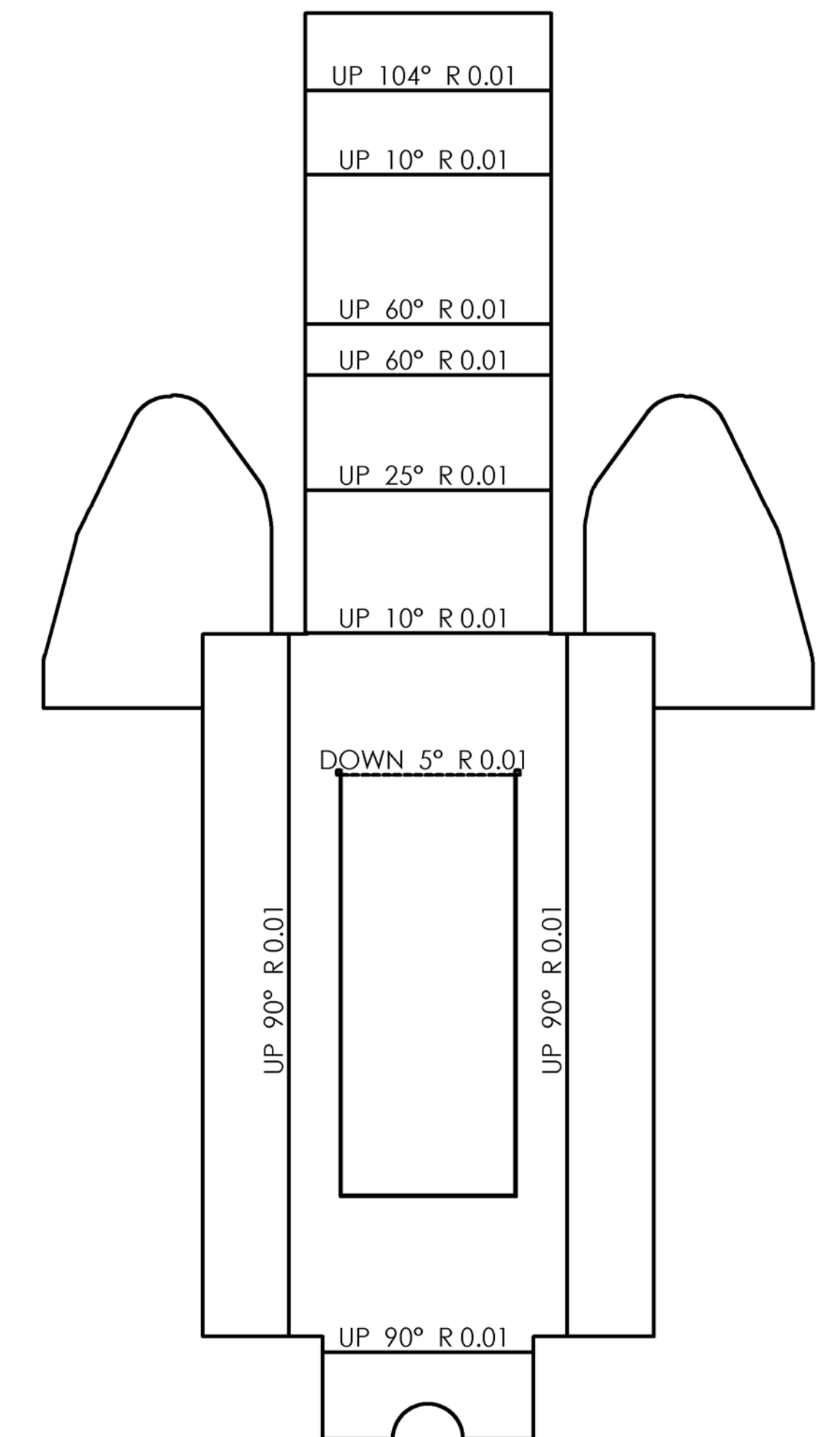
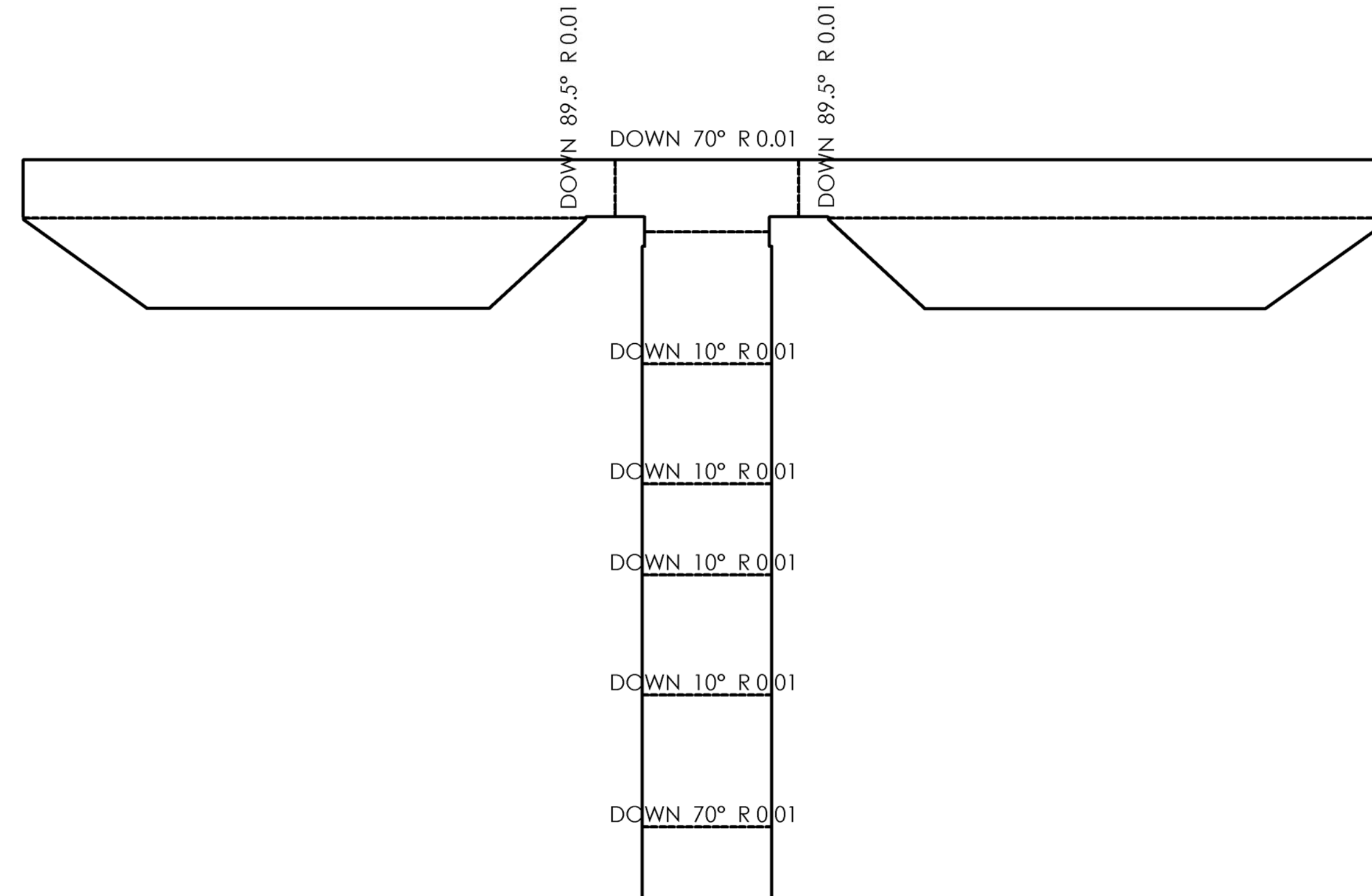
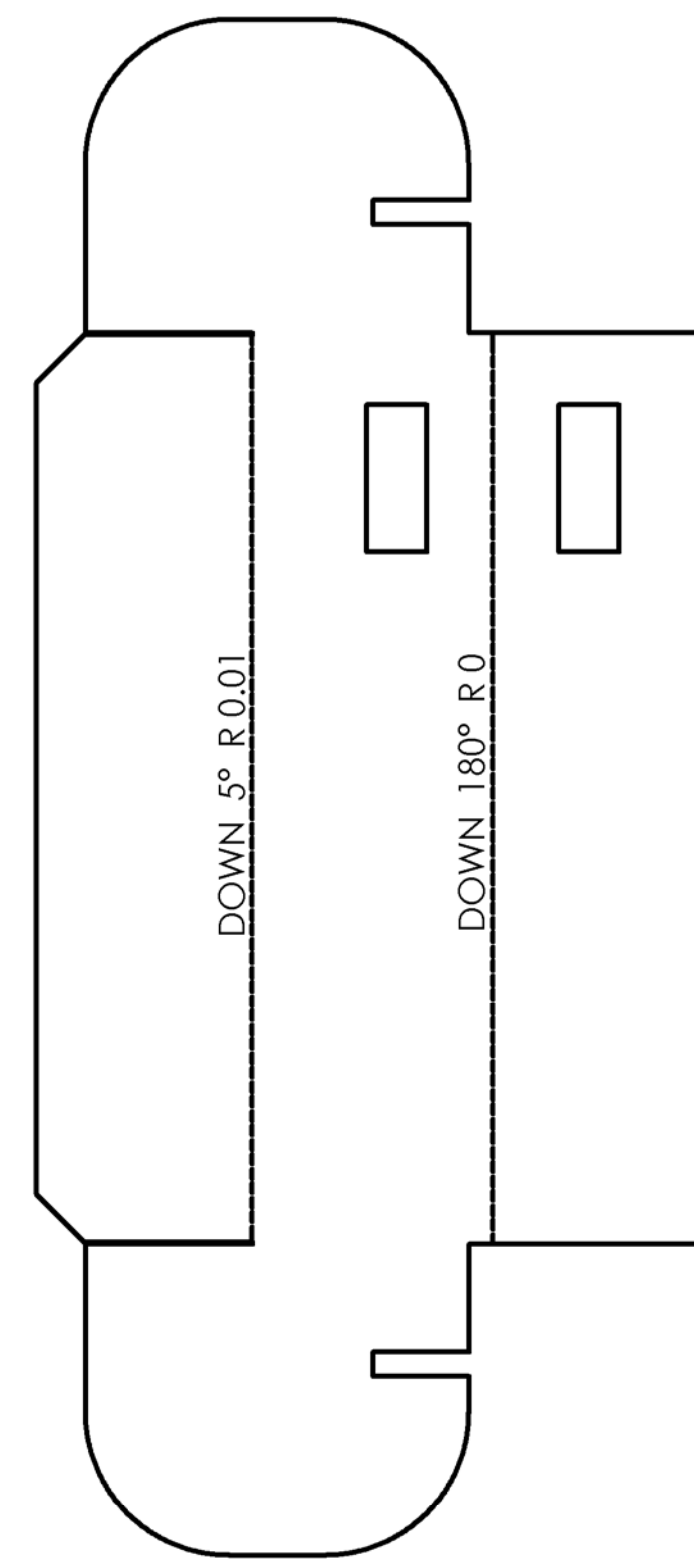
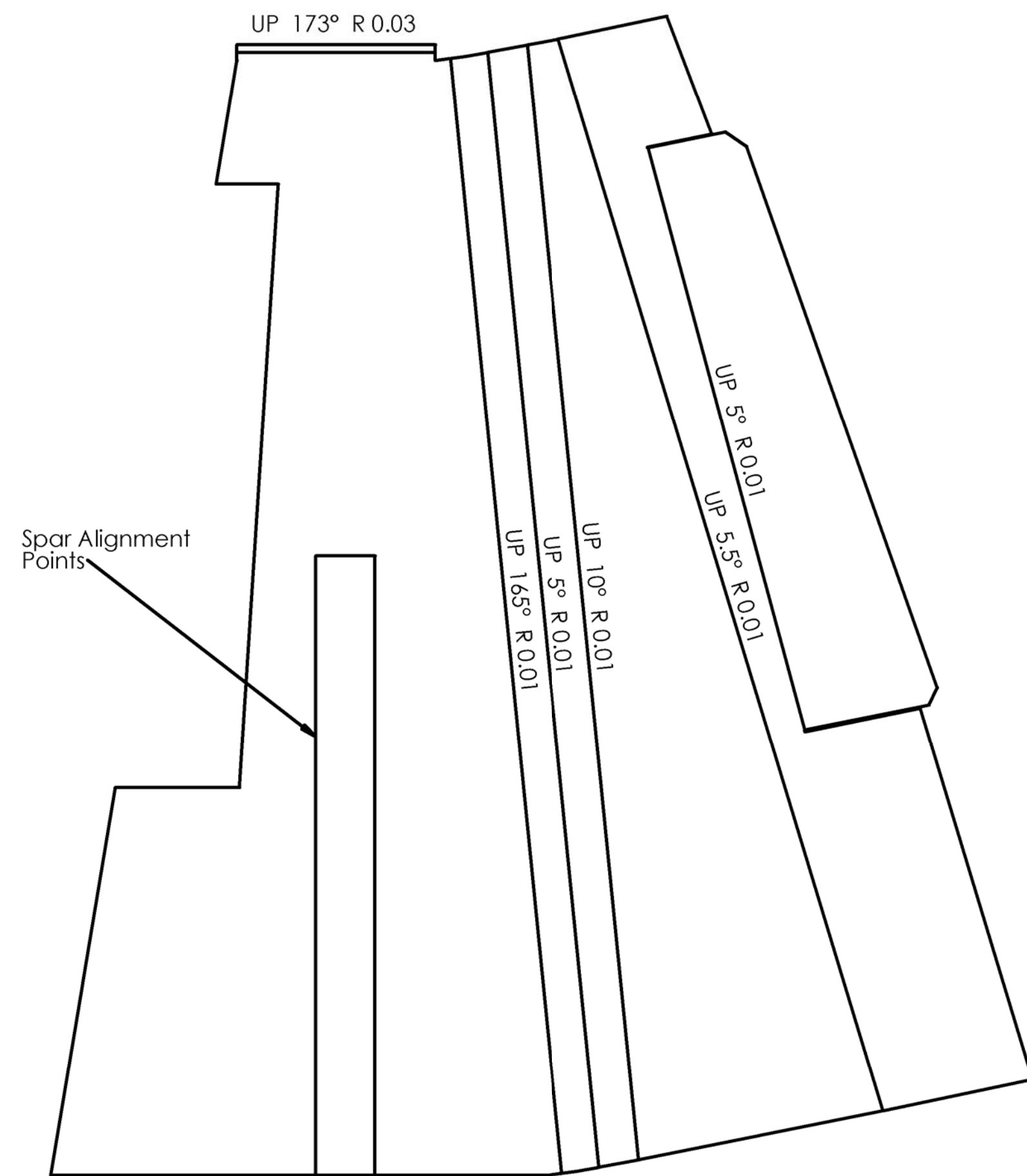
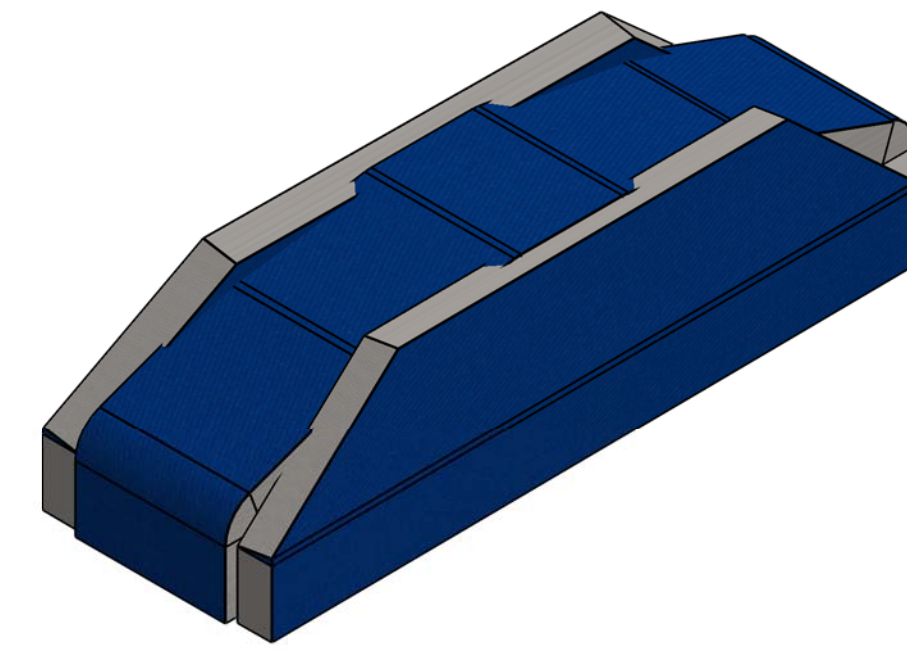

PROPRIETARY AND CONFIDENTIAL
THE INFORMATION CONTAINED IN THIS DRAWING IS THE SOLE PROPERTY OF [INSERT COMPANY NAME HERE]. ANY REPRODUCTION IN PART OR AS A WHOLE WITHOUT THE WRITTEN PERMISSION OF [INSERT COMPANY NAME HERE] IS PROHIBITED.

UNLESS OTHERWISE SPECIFIED:		NAME	DATE
DIMENSIONS ARE IN INCHES	TOLERANCES:	DRAWN	CHECKED
FRACTIONAL	ANGULAR MATCH	ENG APPR.	ENG APPR.
TWO PLACE DECIMAL	BEND	DWG APPR.	DWG APPR.
THREE PLACE DECIMAL	D.A.		
REFER TO DRAWING TOLERANCE PER:			
MATERIAL			
FINISH			
APPLICATION	DO NOT SCALE DRAWING		

SIZE	DWG. NO.	REV
D	FT Mini P-38	
SCALE: 1:1	WEIGHT:	SHEET 2 OF 3

P-38/61 Black Lightning Patterns
 Designer-Carlos A Rodriguez

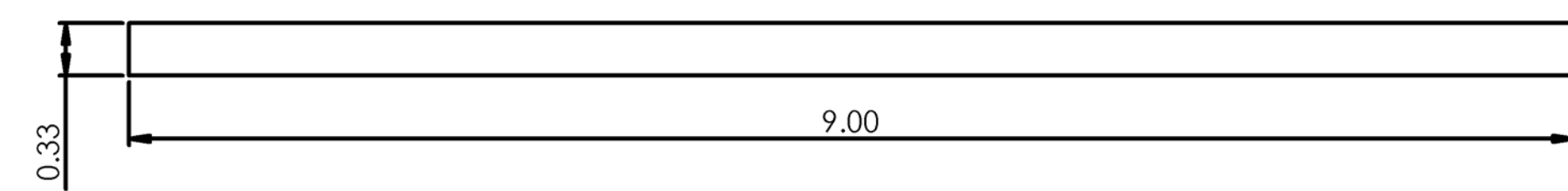
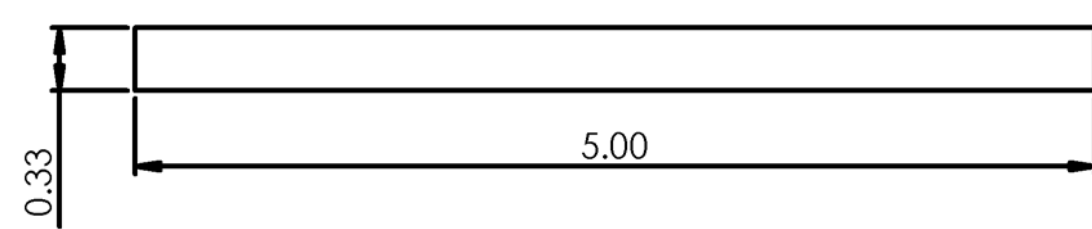
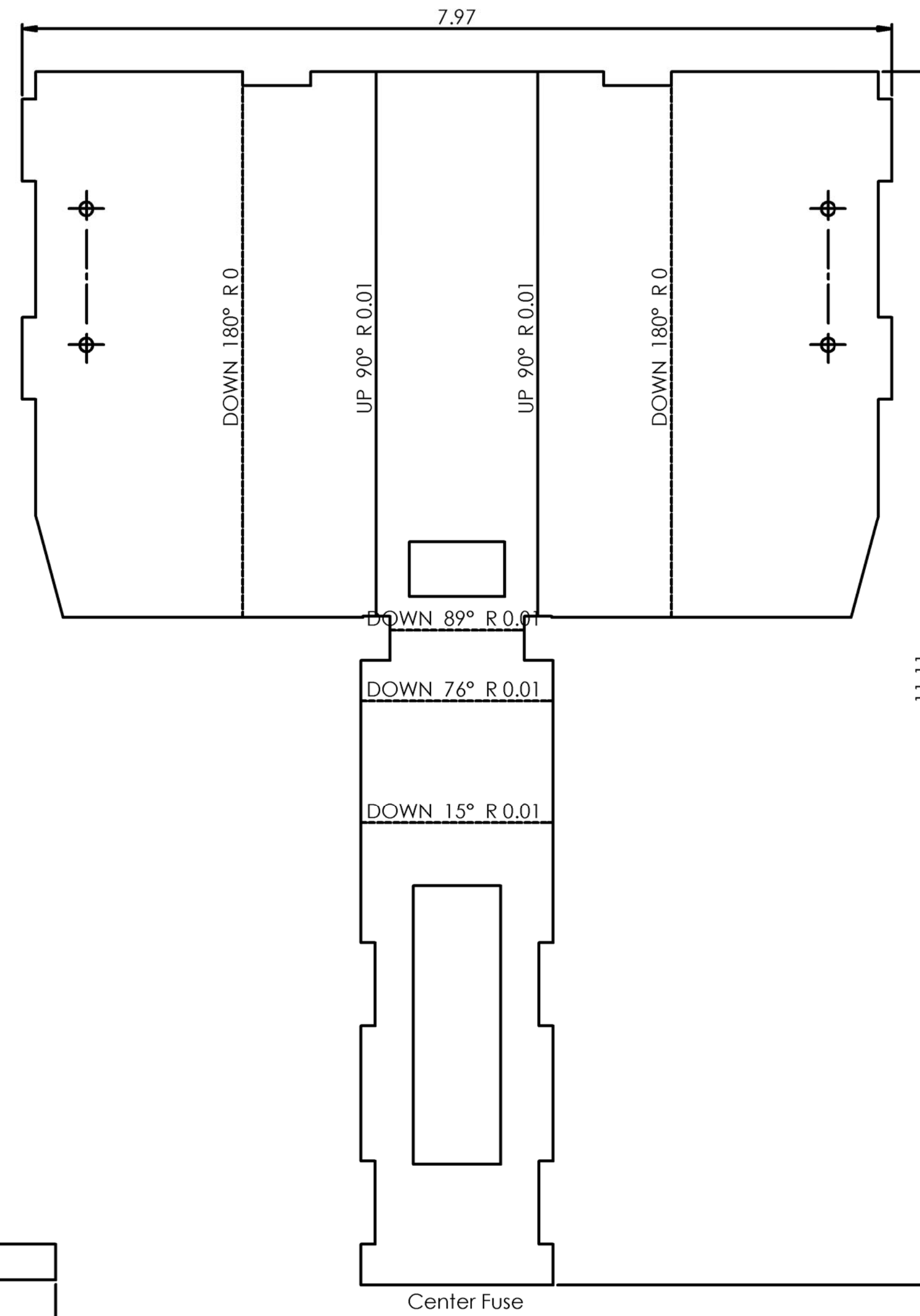
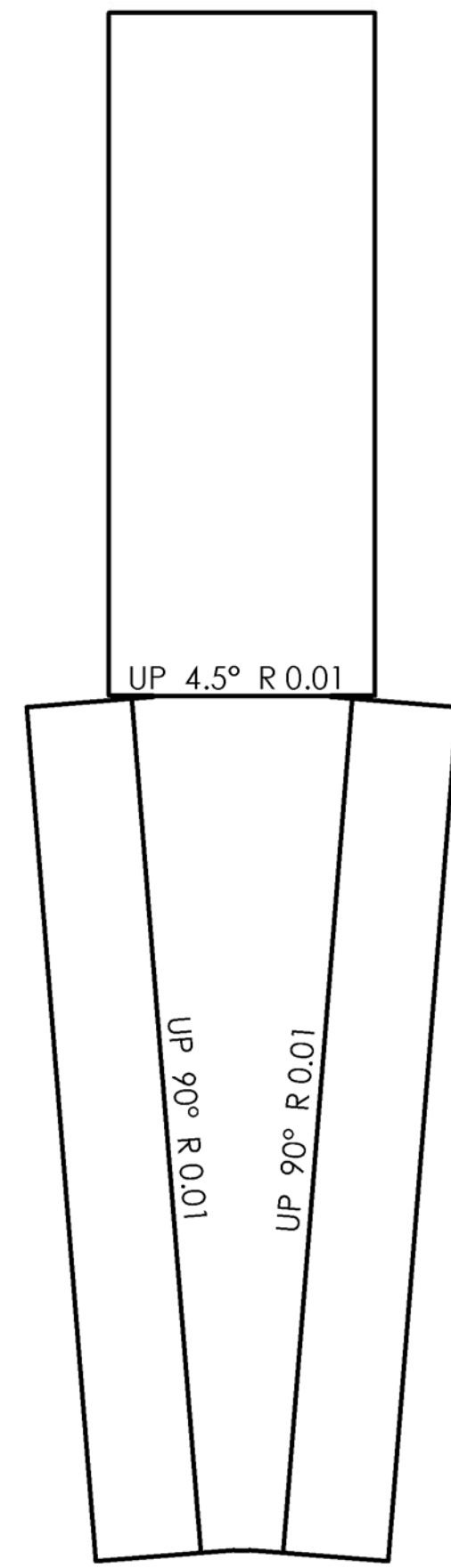
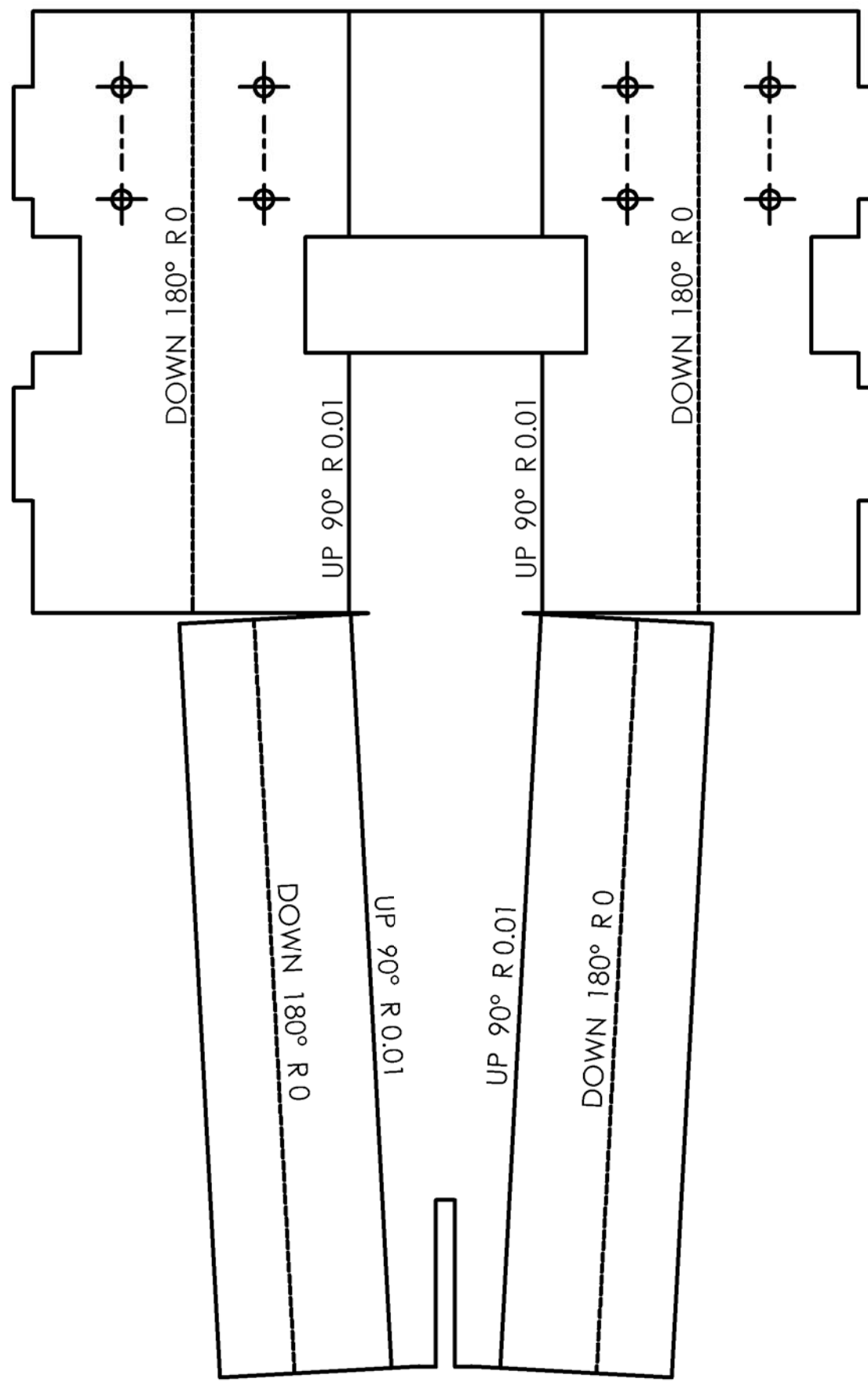
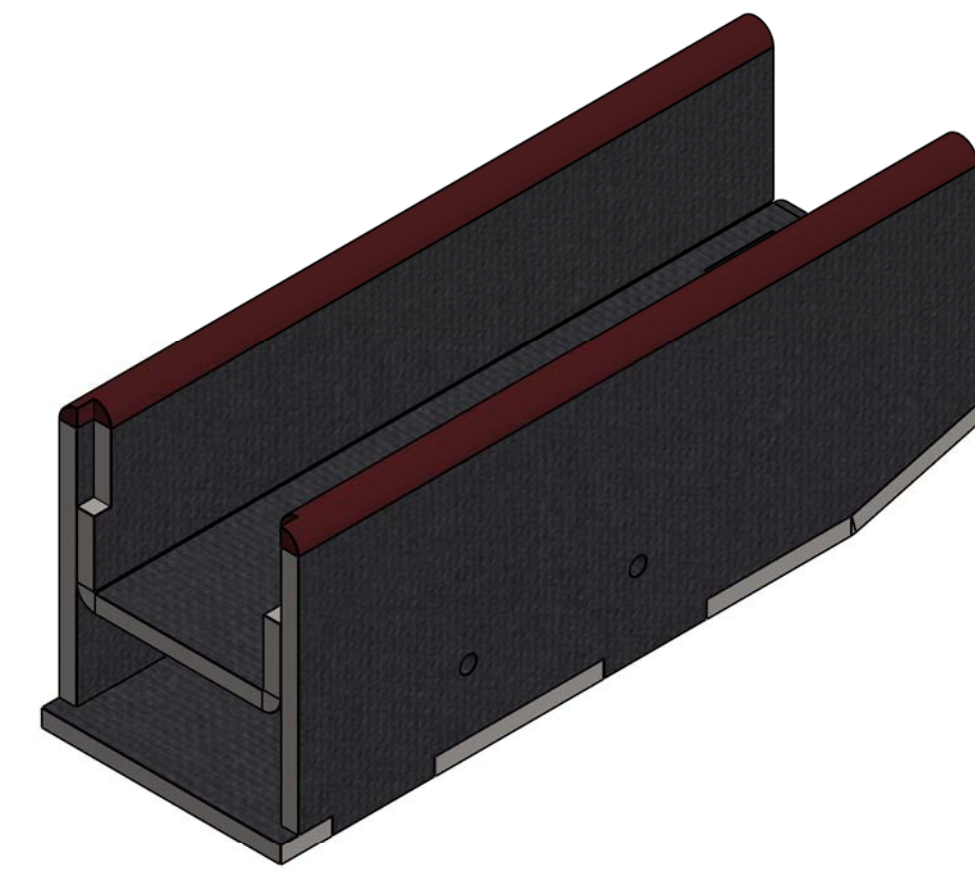
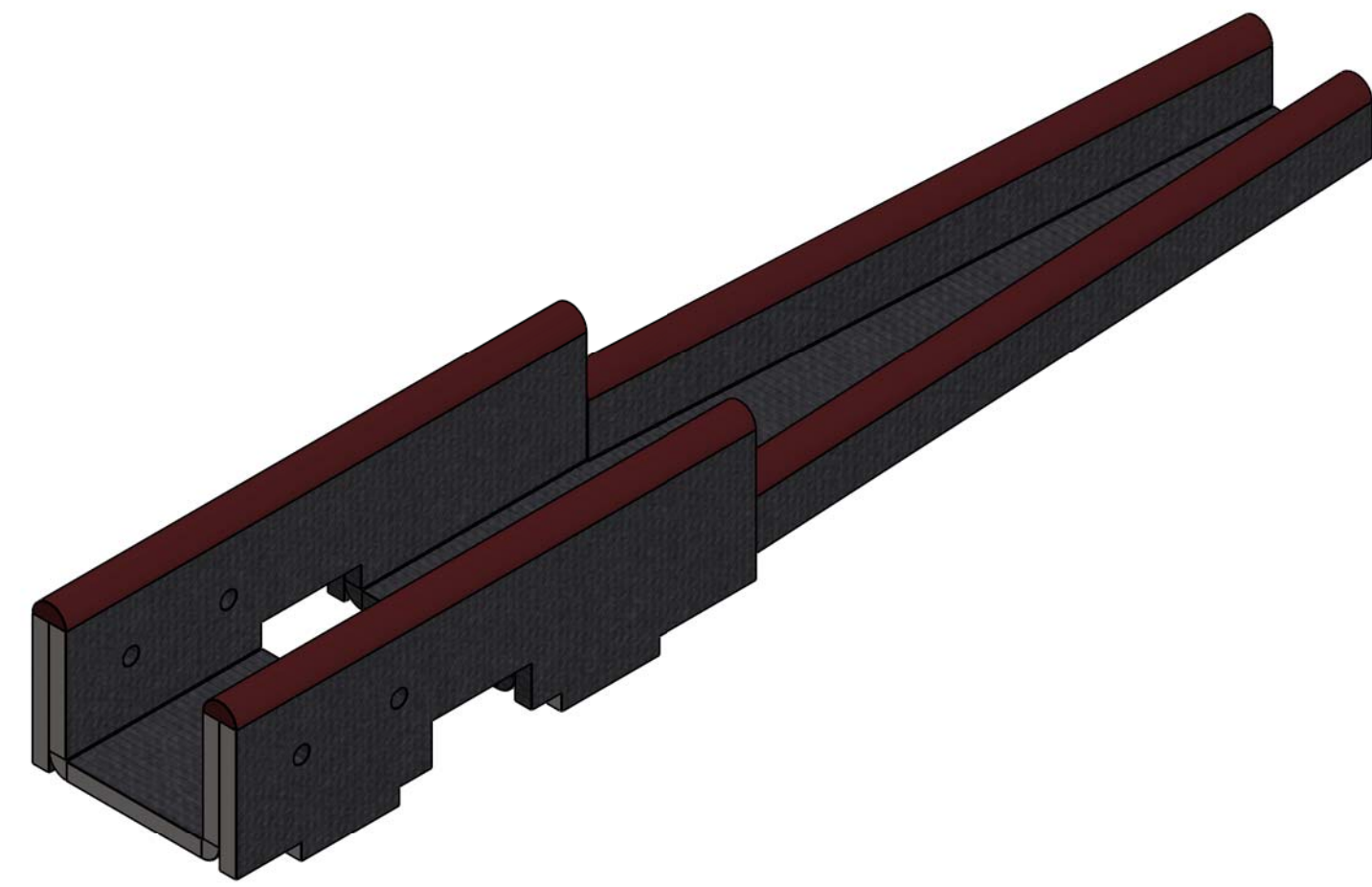

PROPRIETARY AND CONFIDENTIAL
 THE INFORMATION CONTAINED IN THIS
 DRAWING IS THE SOLE PROPERTY OF
 ©BERT COMPANY NAME HERE. ANY
 REPRODUCTION IN PART OR AS A WHOLE
 WITHOUT THE WRITTEN PERMISSION OF
 ©BERT COMPANY NAME HERE IS
 PROHIBED.

UNLESS OTHERWISE SPECIFIED:		NAME	DATE
DIMENSIONS ARE IN INCHES	TOLERANCES:	DRAWN	
FRACTIONAL	ANGULAR MATCH	CHECKED	
TWO PLACE DECIMAL	BEND	ENG APPR.	
THREE PLACE DECIMAL		USG APPR.	
REFER TO DRAWING TOLERANCE		D.A.	
MATERIAL		COMMENTS:	
NEXT ASSY	USED ON		
APPLICATION	DO NOT SCALE DRAWING		

SIZE	DWG. NO.	REV
D	FT Mini P-38	
SCALE: 1:1	WEIGHT:	SHEET 3 OF 3