

LEFT SIDE OMITTED FOR CLARITY
NOTE: ↓ INDICATES FUSELAGE SIDE OUTLINE

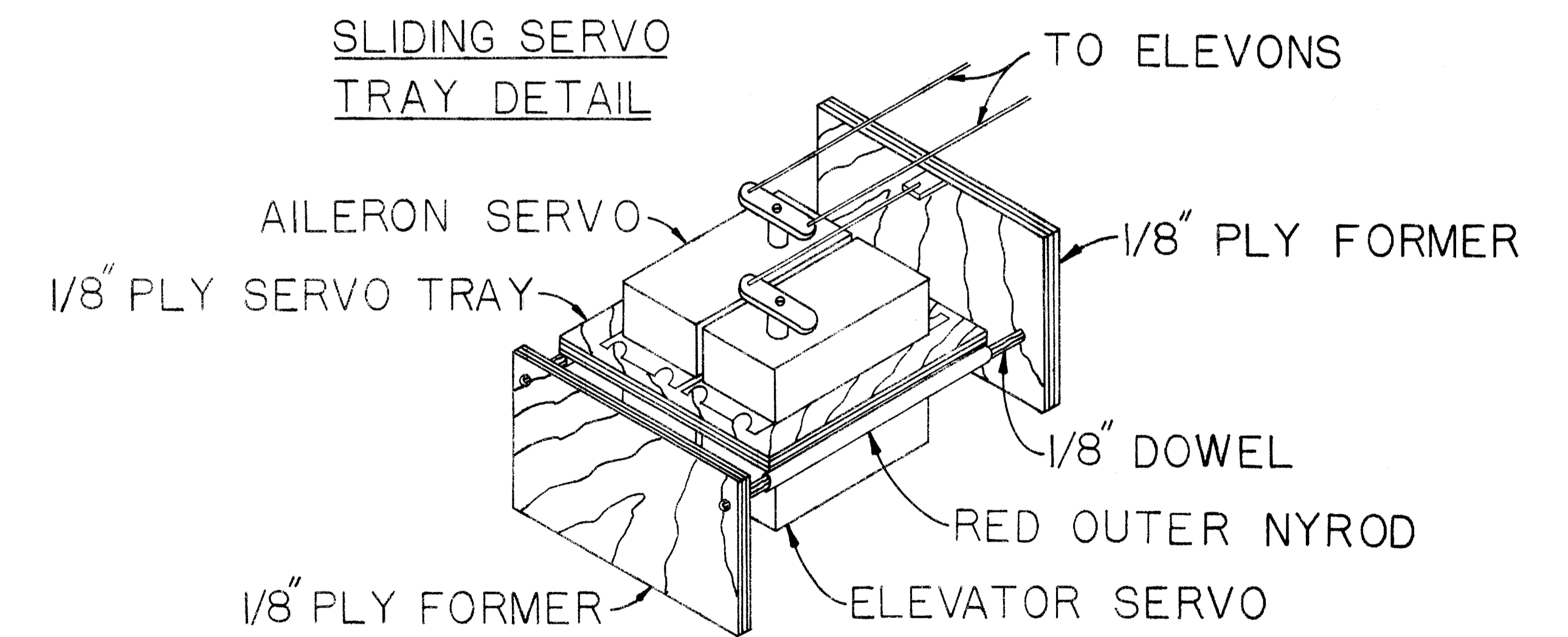
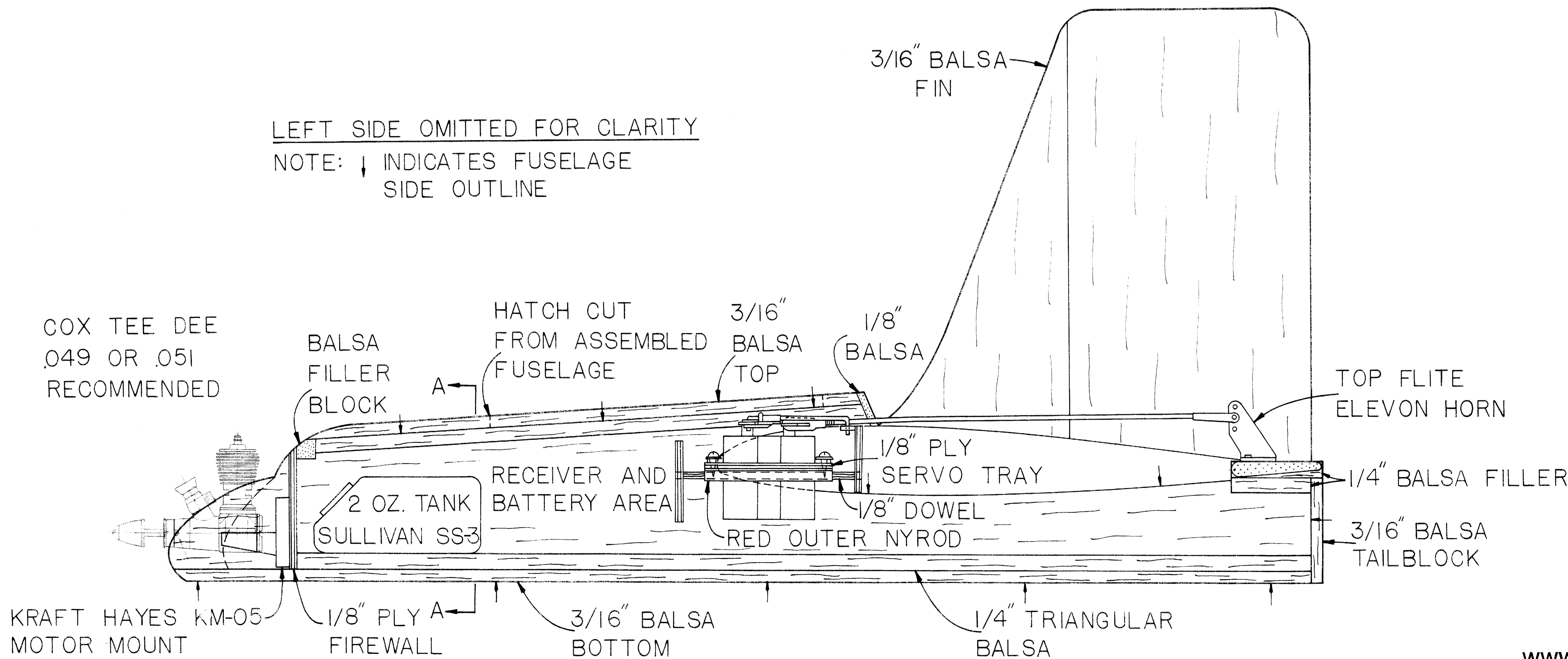

ALL COMMERCIAL RIGHTS RESERVED

SIMITAR

DESIGNED BY BILL EVANS
DRAWN BY B. ROBERTSON

INKED BY CHUCK FELTON

0 1 2 3 4 5 6

PLAN NO. 669