



www.flitetest.com

FT Corsair

Designed By: John Overstreet
in collaboration with Flite Test
Drawing By: Dan Sponholz
Version: 1.0
Date: 2019.03.09



GENERAL SPECIFICATIONS:

LENGTH:	30.75 in		781 mm
CG:	2.00 in		50.8 mm
WINGSPAN:	46.00 in		1168 mm
WING AREA:	355.5 in ²		22.9 dm ²
DRY WEIGHT:	26.0 oz.		737 g
ALL UP WEIGHT:	36.0 oz.		1020 g
WING LOADING:	14.6 oz/ft ²		44.6 g/dm ²
WCL:	9.3		
THROWS:	12°		
EXPO:	30%		
CHANNELS:	4 [THR AIL ELE RUD]		

RECOMMENDED ELECTRONICS:

MOTOR:	2218B 1080 kv
PROPELLER:	10 x 4.7
ESC:	35A min.
SERVOS:	4 x 9 g
BATTERY:	2200-2800 mAh 3S or 4S

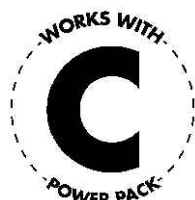

BUILD SKILL LEVEL:



PILOT SKILL LEVEL:





FT Corsair: Full-Size Key

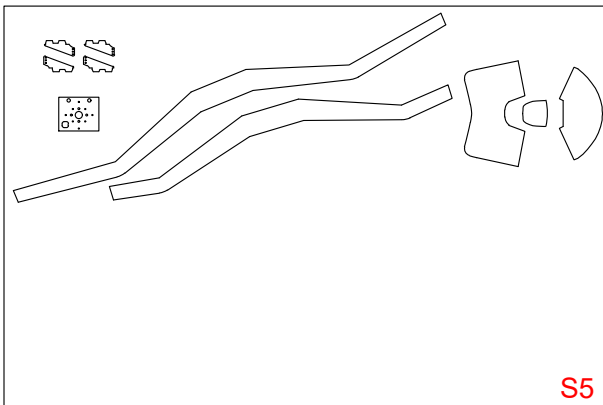
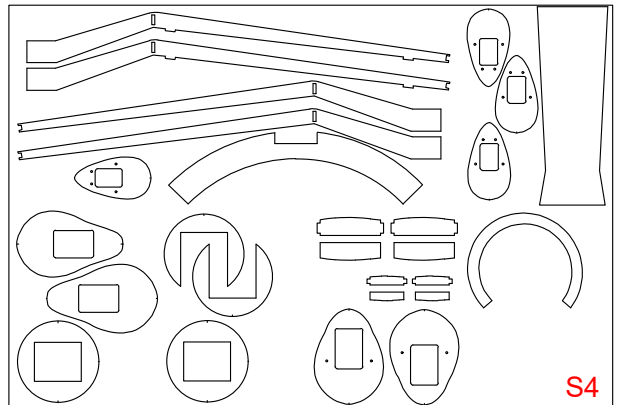
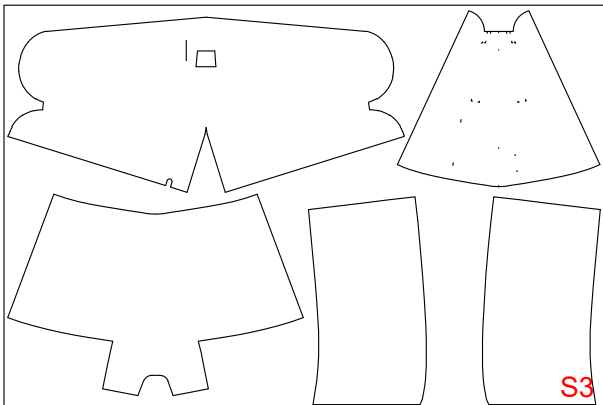
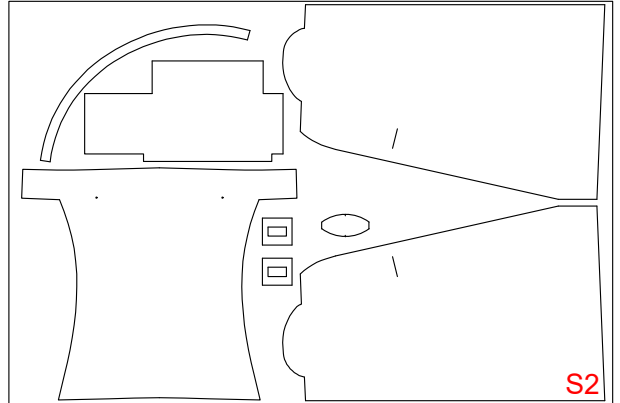
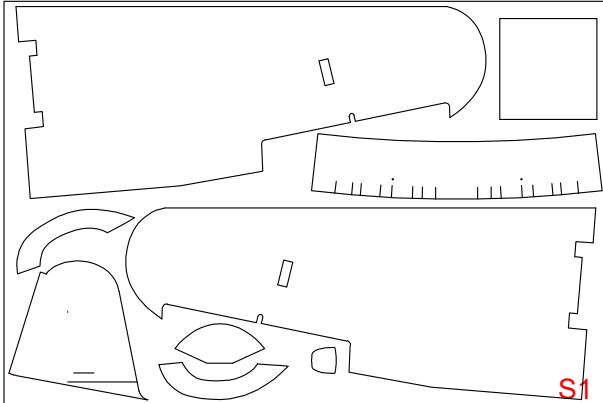



Drawing Key



FOLD TYPES

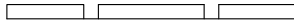
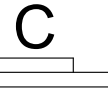
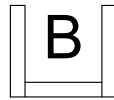
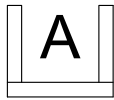

A - FOLD (ABOVE)

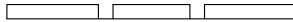

B - FOLD (BESIDE)

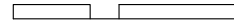

C - FOLD (COVER)

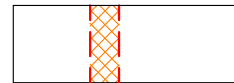
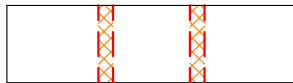
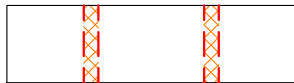

LINE TYPE/COLOR

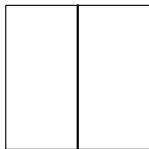

CUT

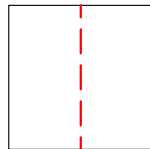
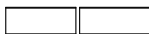

50% SCORE

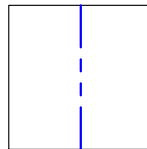
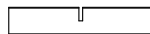

CREASE

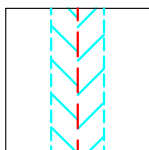

45° DOUBLE BEVEL

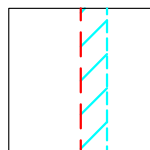

45° SINGLE BEVEL

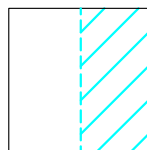

EDGE BEVEL

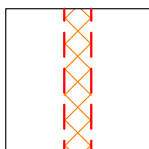
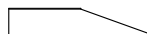

CAVITY

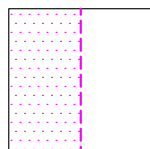

REMOVE PAPER

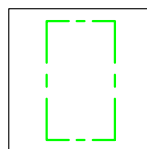

REFERENCE/
OPTIONAL



SYMBOLS

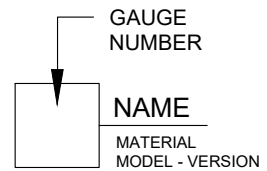
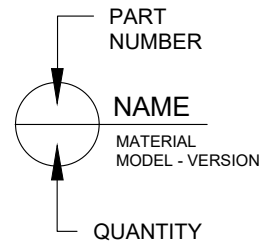

CENTER OF GRAVITY (CG)

FT Corsair

Designed By: John Overstreet
in collaboration with Flite Test
Drawing By: Dan Sponholz
Version: 1.0
Date: 2019.03.09

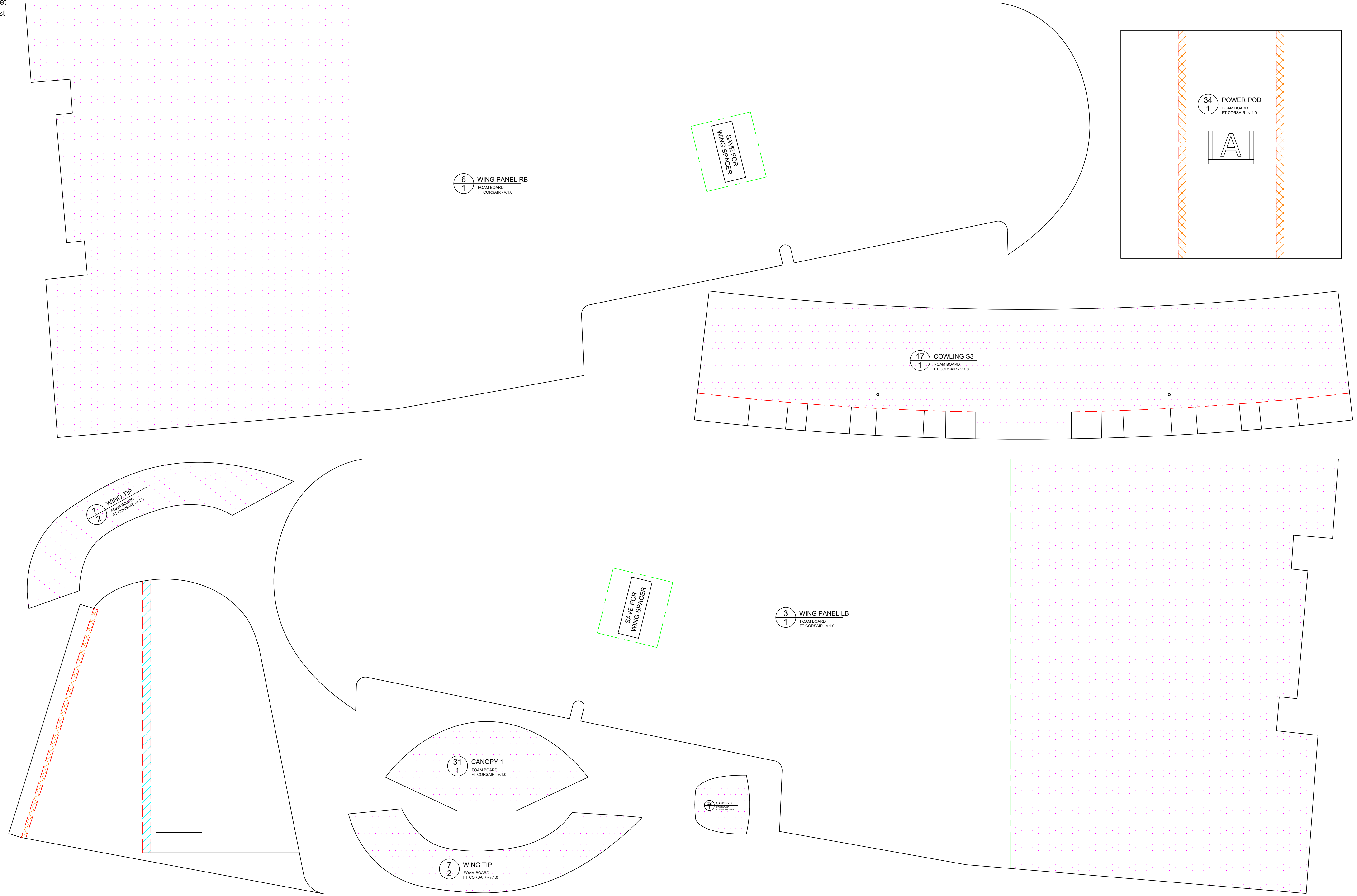
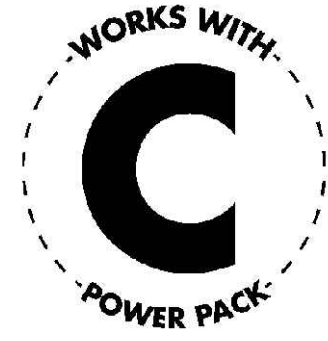

FT Corsair

Designed By: John Overstreet
in collaboration with Flite Test
Drawing By: Dan Sponholz
Version: 1.0
Date: 2019.03.09

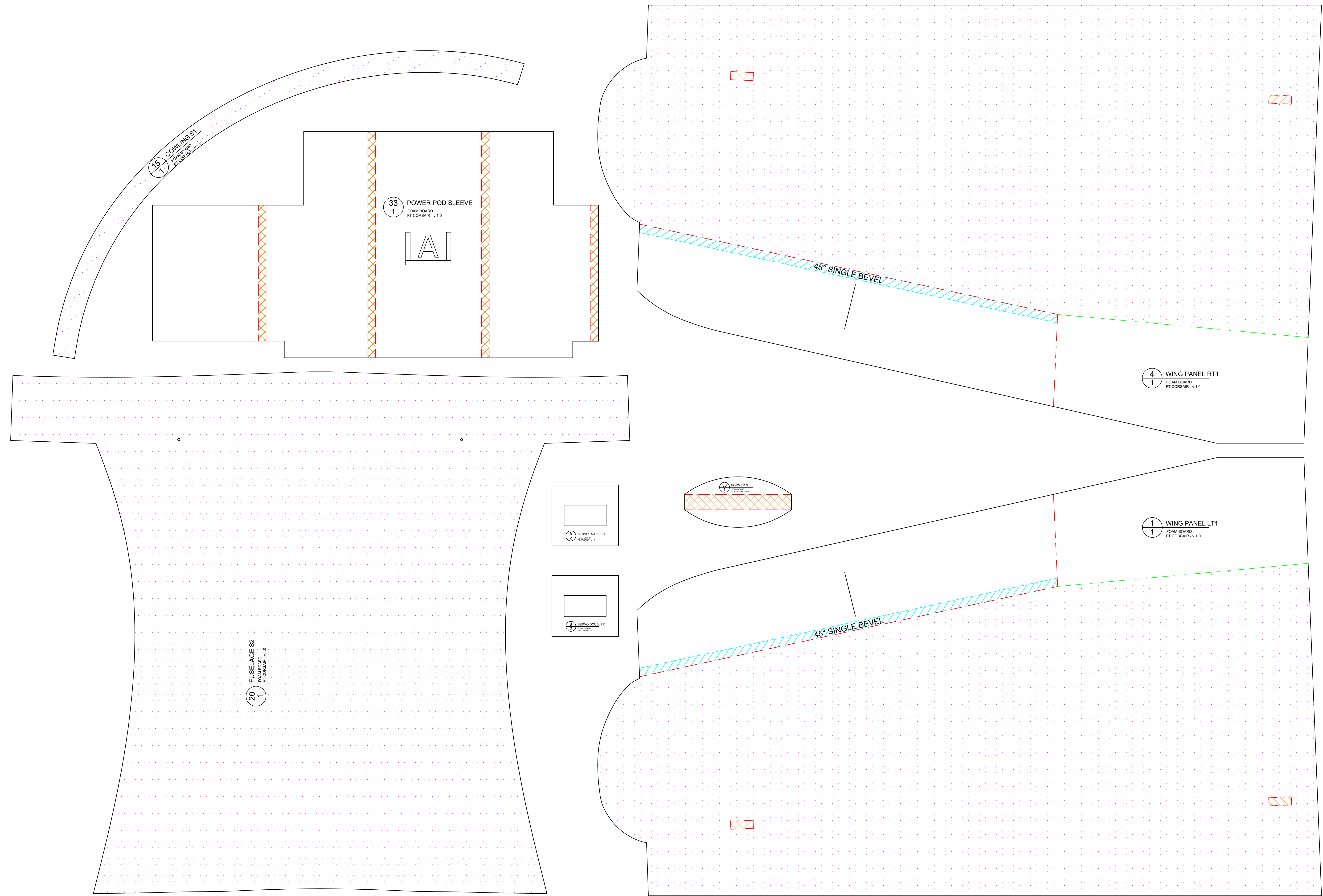

FT Corsair

Designed By: John Overstreet
in collaboration with Flite Test
Drawing By: Dan Sponholz
Version: 1.0
Date: 2019.03.09

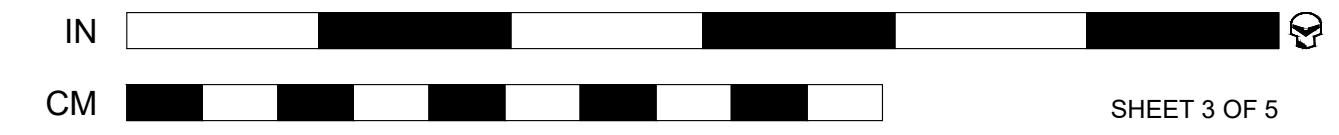
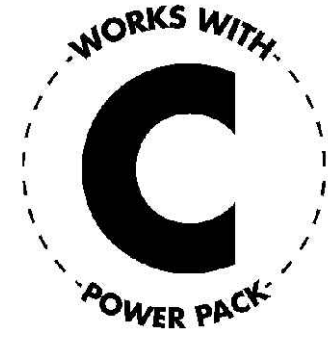

SHEET 3 OF 5

Template Version 6.0

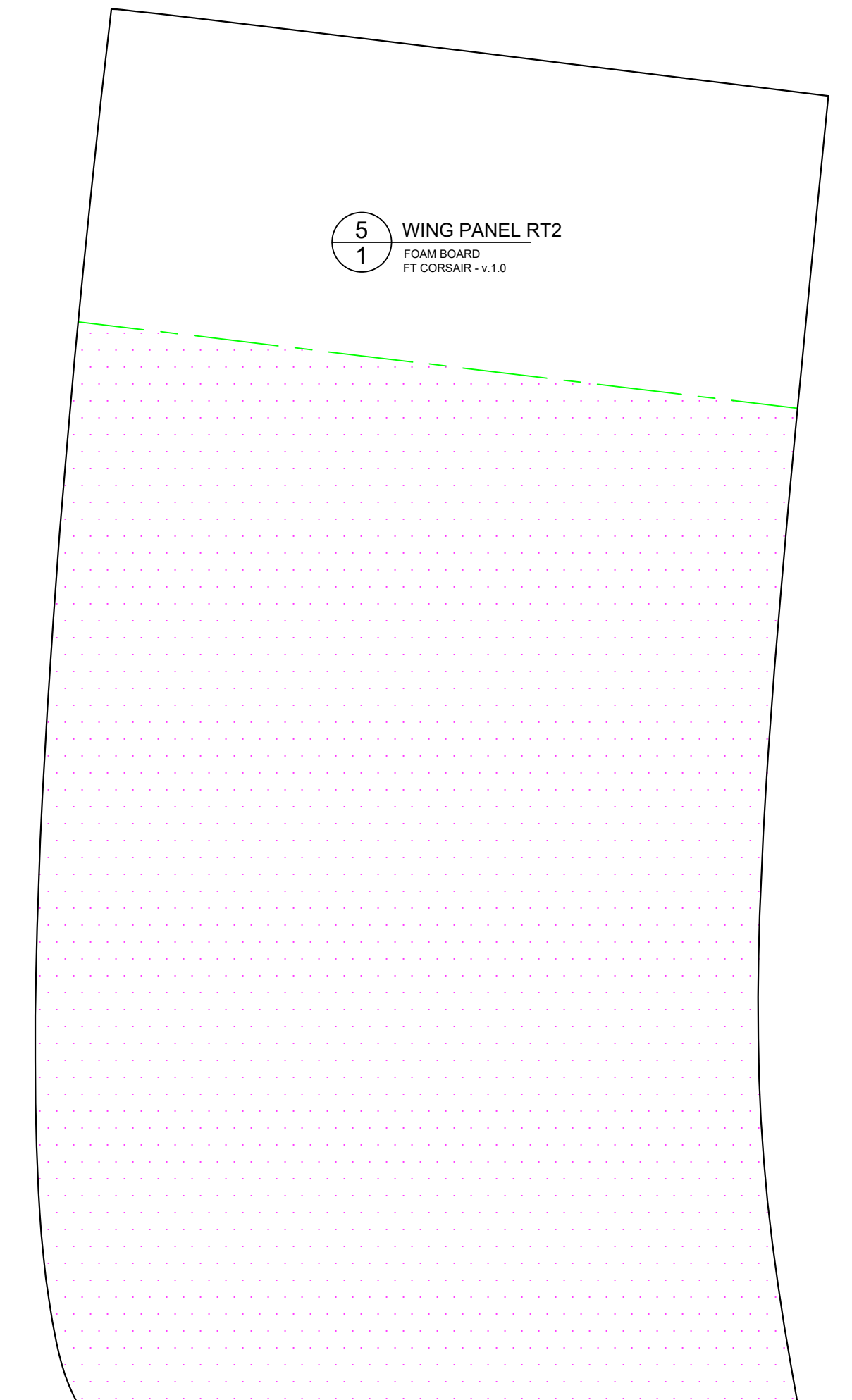
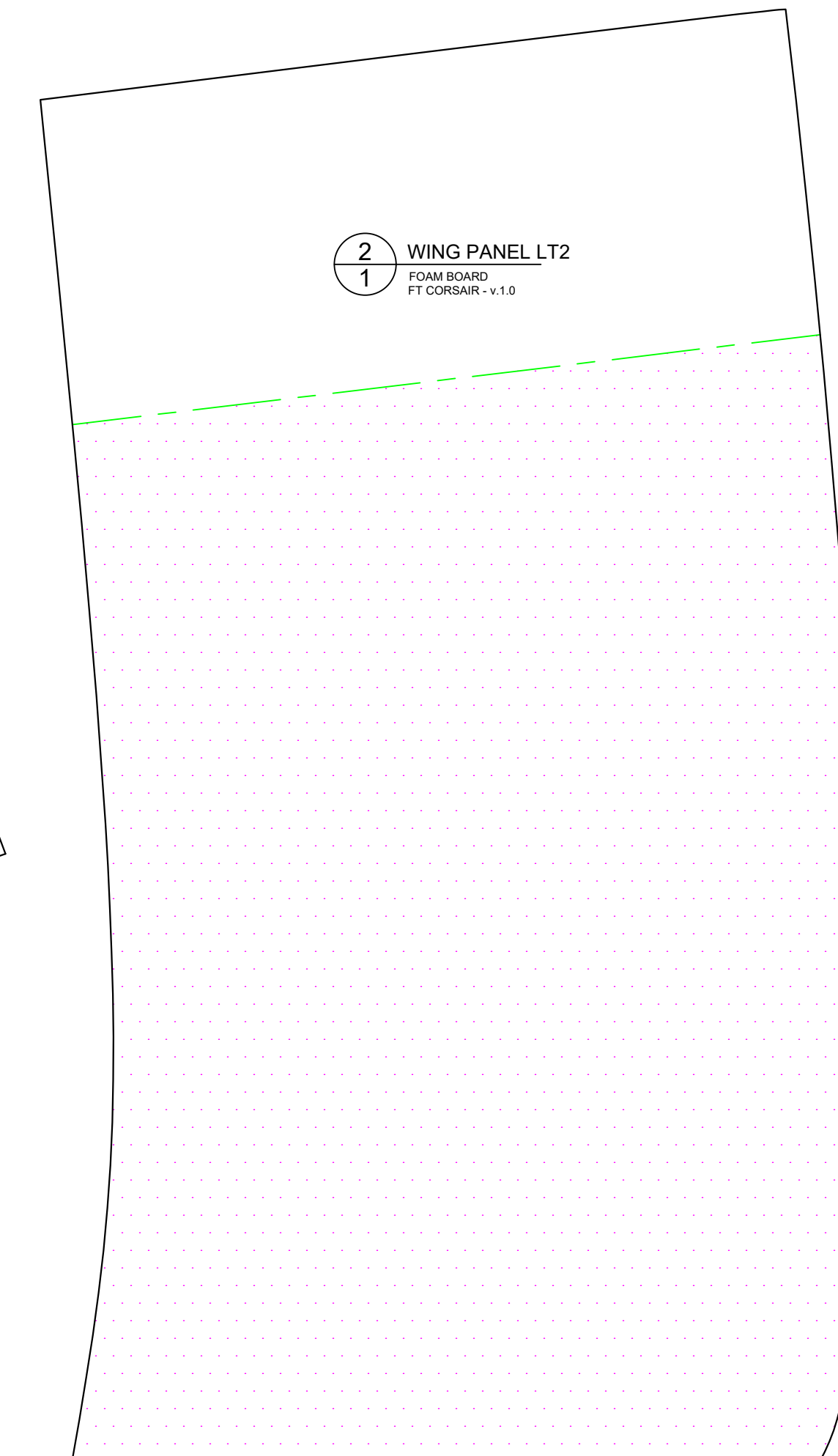
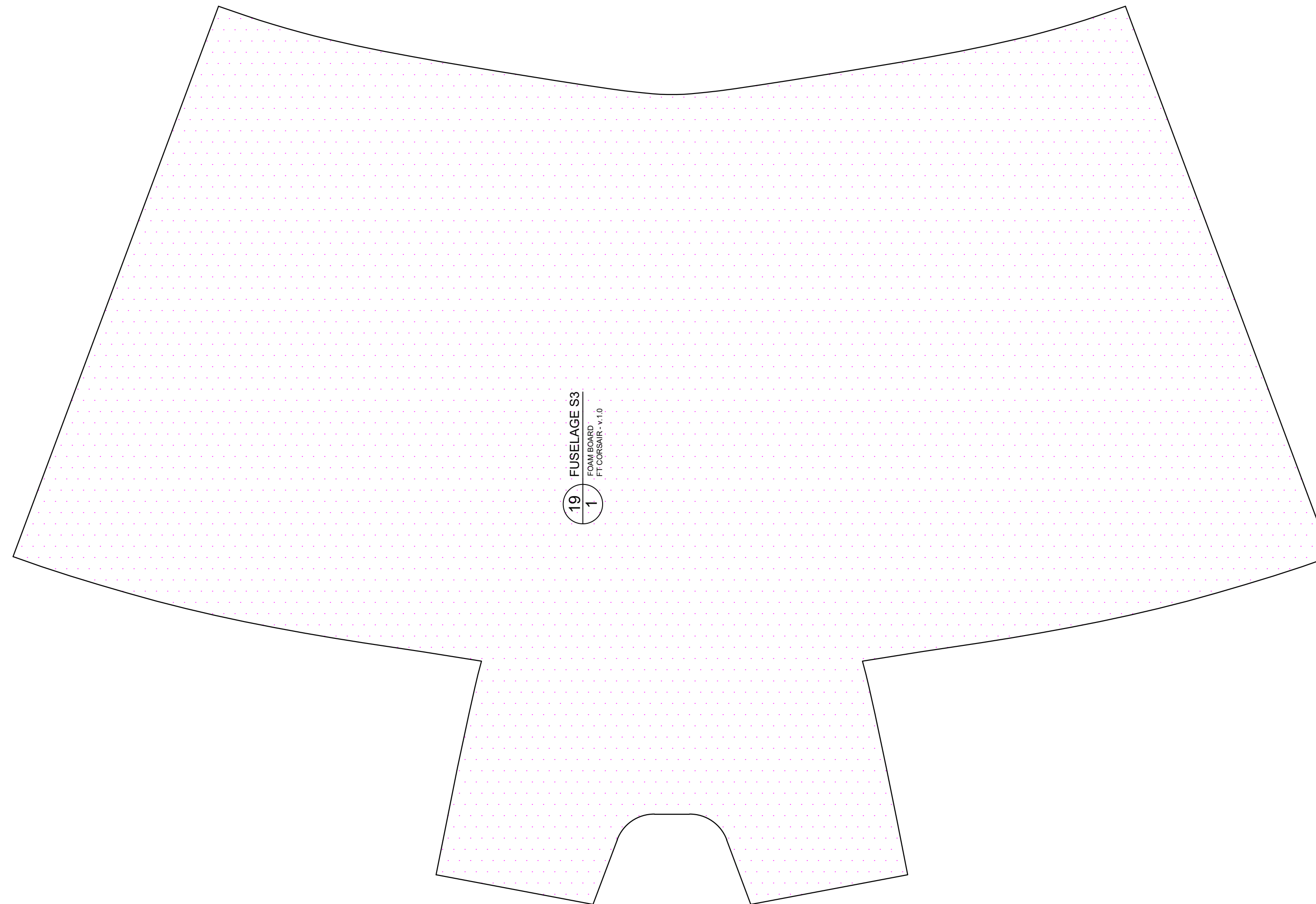
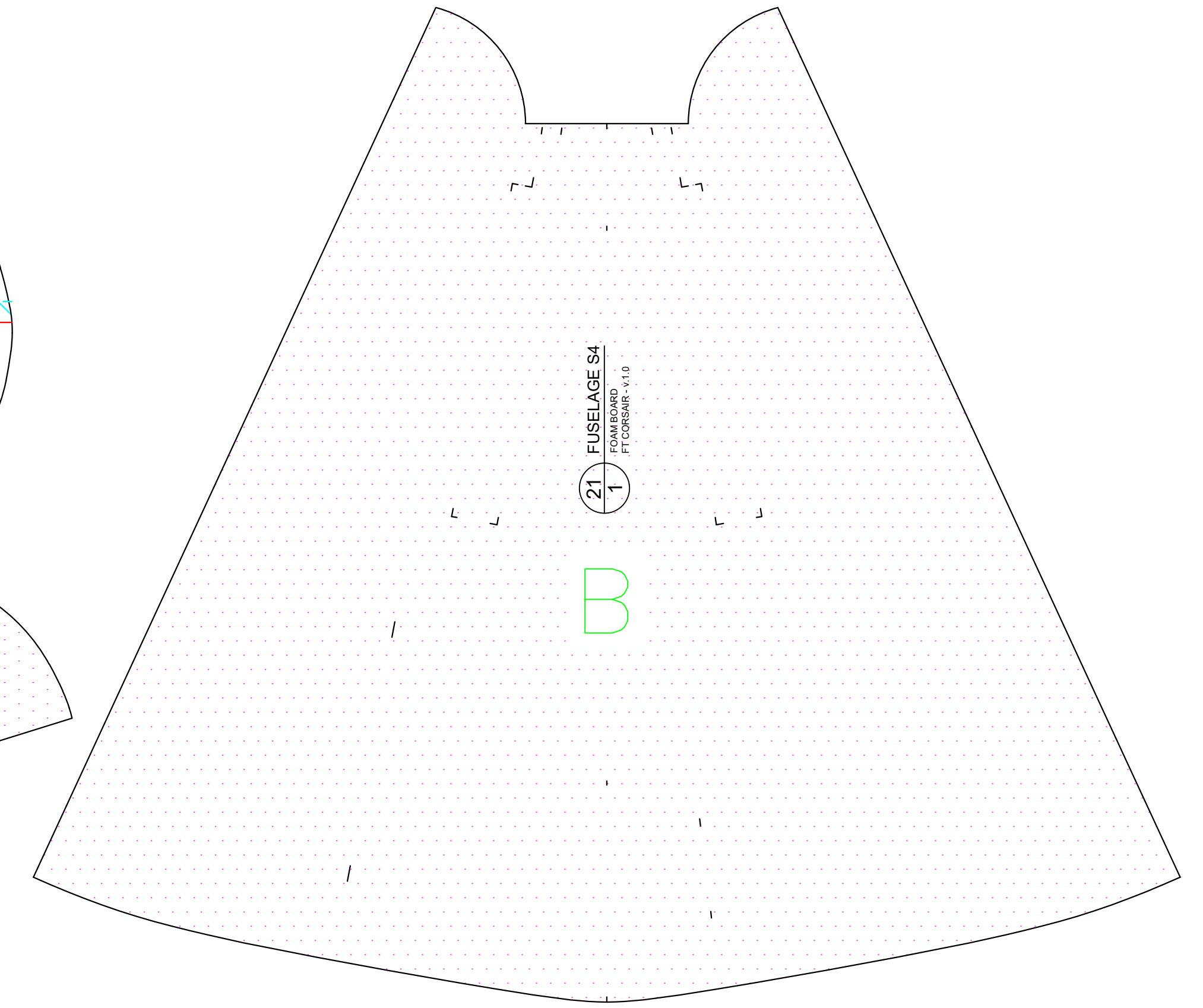
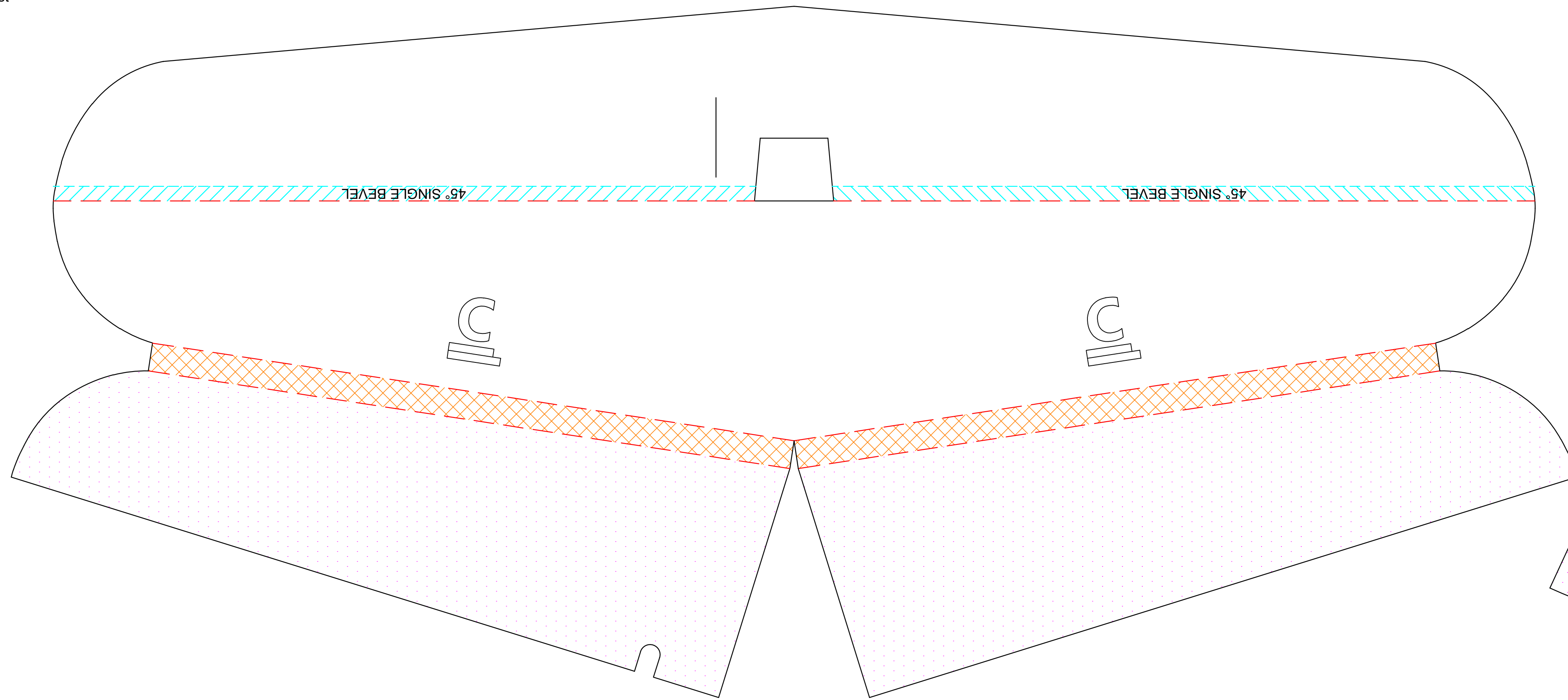

© 2019 Flite Test, LLC. Plans provided free of charge. Copies allowed for personal use only. Not for commercial use.

FT Corsair

Designed By: John Overstreet
in collaboration with Flite Test
Drawing By: Dan Sponholz
Version: 1.0
Date: 2019.03.09

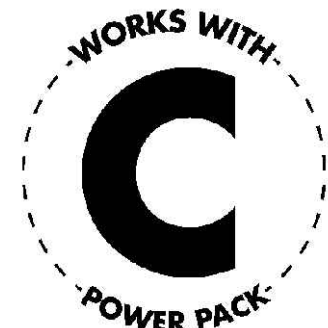

The main assembly template consists of several large parts and smaller spacers:

- FOAM SPAR A** (9/2): Two long, tapered pieces for the wing structure.
- FOAM SPAR B** (10/2): Two long, tapered pieces for the wing structure.
- FUSELAGE S1** (17/1): The main fuselage piece, shown with a dotted pattern.
- FORMER A** (22/2) and **FORMER B1** (23/2): Two teardrop-shaped pieces for the fuselage.
- FORMER B2** (24/2): A teardrop-shaped piece for the fuselage.
- FORMER C1** (25/2) and **FORMER C2** (26/2): Two teardrop-shaped pieces for the fuselage.
- FORMER D** (27/2) and **FORMER E** (28/2): Two circular pieces for the fuselage.
- FORMER F** (29/2): Two circular pieces for the fuselage.
- SPAR SPACER A1** (11/2) and **SPAR SPACER A2** (12/2): Four rectangular spacers for the wing.
- SPAR SPACER B1** (13/2) and **SPAR SPACER B2** (14/2): Four small rectangular spacers for the wing.
- COWLING S2** (16/1): A curved piece for the fuselage cowling.
- BOTTOM COVER** (35/1): A large rectangular piece with a dotted pattern for the bottom cover.
- SAVE FOR WING TAB**: Two pieces for the wing tabs, one labeled 'D' and one labeled 'D'.

FT Corsair

Designed By: John Overstreet
in collaboration with Flite Test
Drawing By: Dan Sponholz
Version: 1.0
Date: 2019.03.09

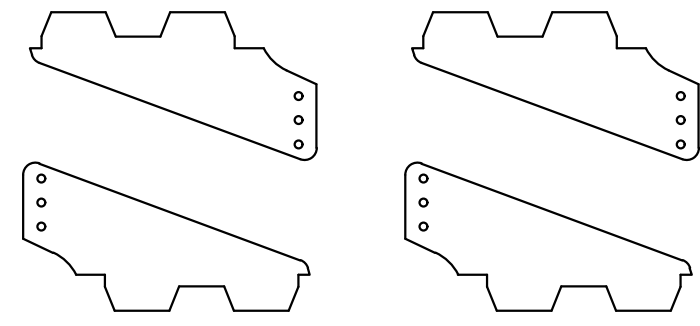
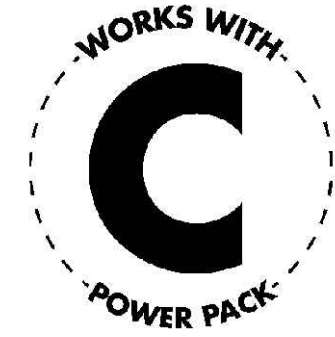

HOBBY GRADE PLYWOOD
3/32" (2.4 mm) THICK

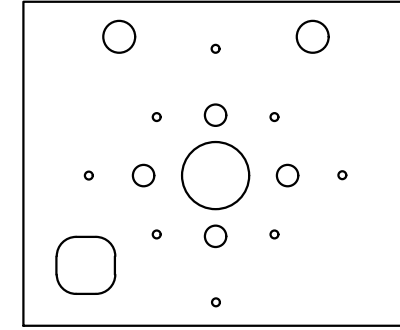

HOBBY GRADE PLYWOOD
3/32" (2.4 mm) THICK

HOBBY GRADE PLYWOOD
3/32" (2.4 mm) THICK

HOBBY GRADE PLYWOOD
3/32" (2.4 mm) THICK

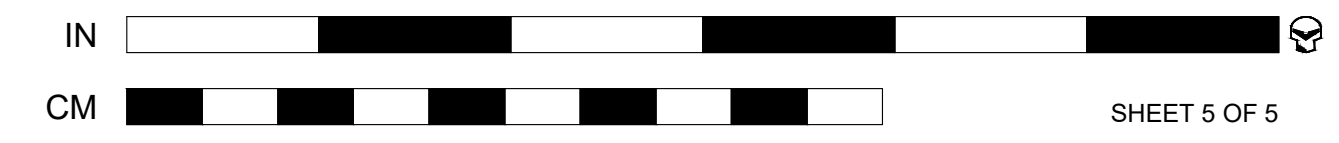

VINYL CANOPY DECALS

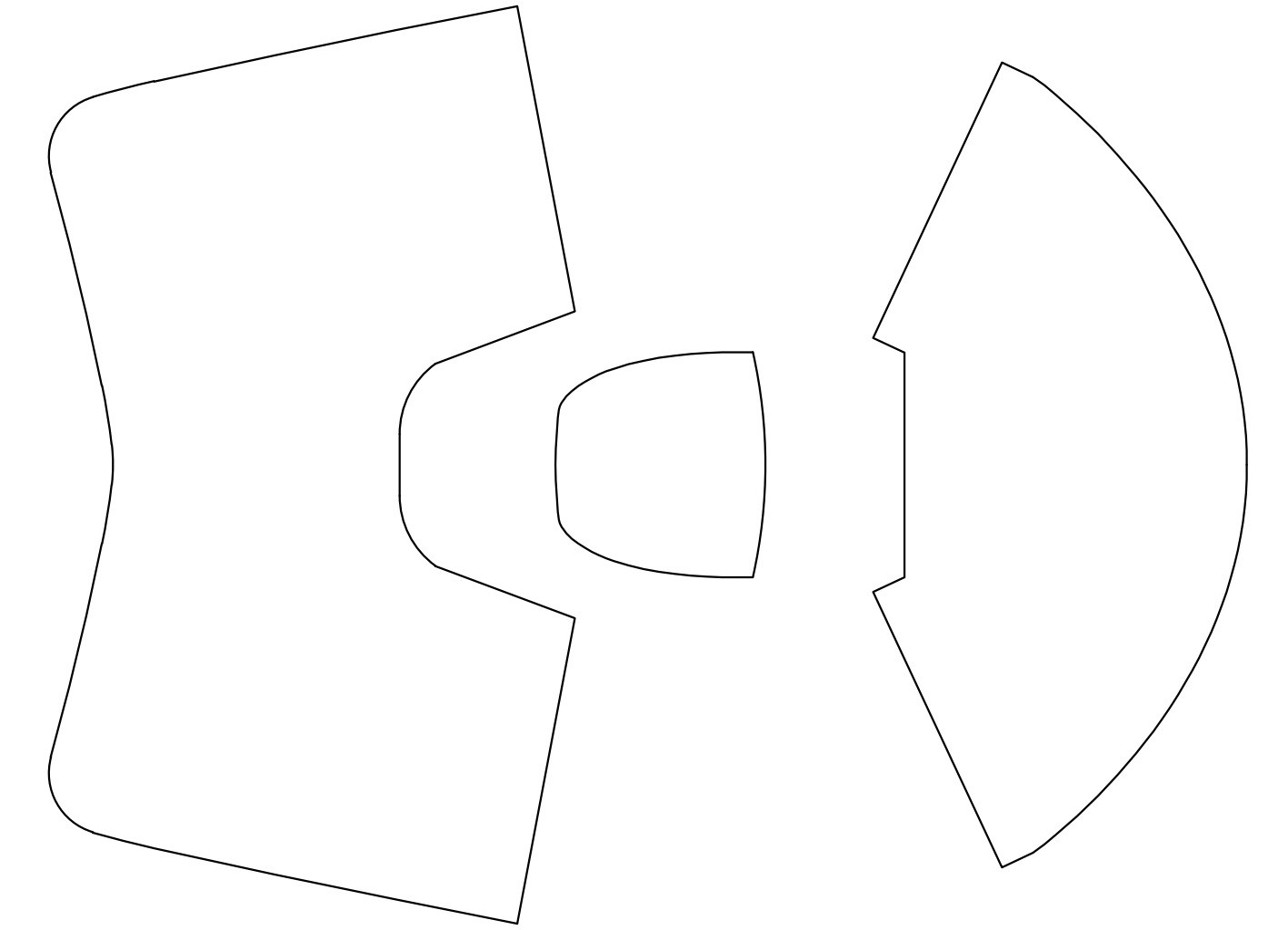

www.flitetest.com