

**OPEN END
NOSE STEERING BOX
1"X1-5/8"**

Front & back plate
1/8" lite ply X2
(Super glue box)

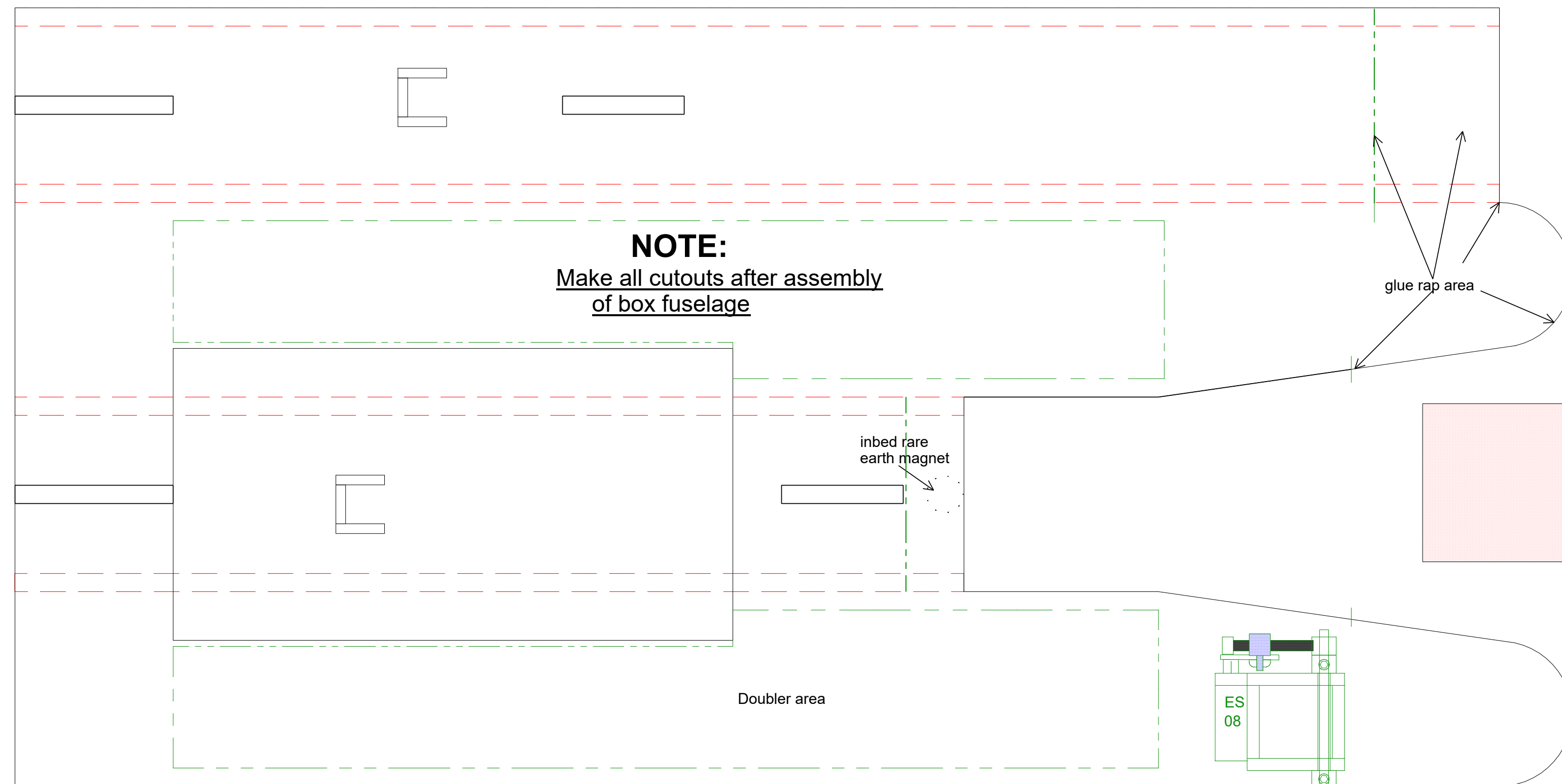

NOTES:
 Motor: 2205 EMax
 ESC: Recomend 30 Amp
 Prop: Gemfam 3 blade 5050 5X5X3
 Battery: LiPo 1300 - 1500 Mah
 Evelons: Flush with wing bottom plain plus 1 to 2 degrees up.
 Evelons Throw: 1/4" up & down
 CG: 3/4" back from leading edge
 Landing Gear Setup: Nose must be elevated above its tail plain to allow air to flow cleanly under wing for take off.

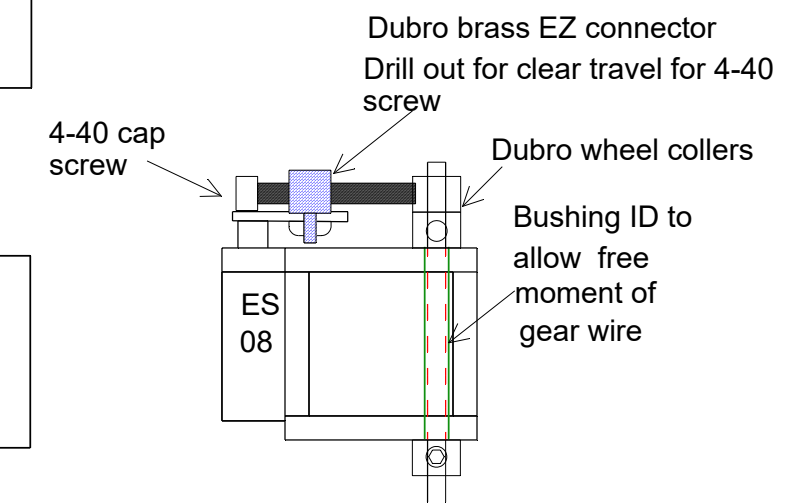
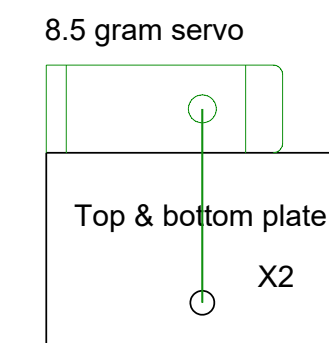
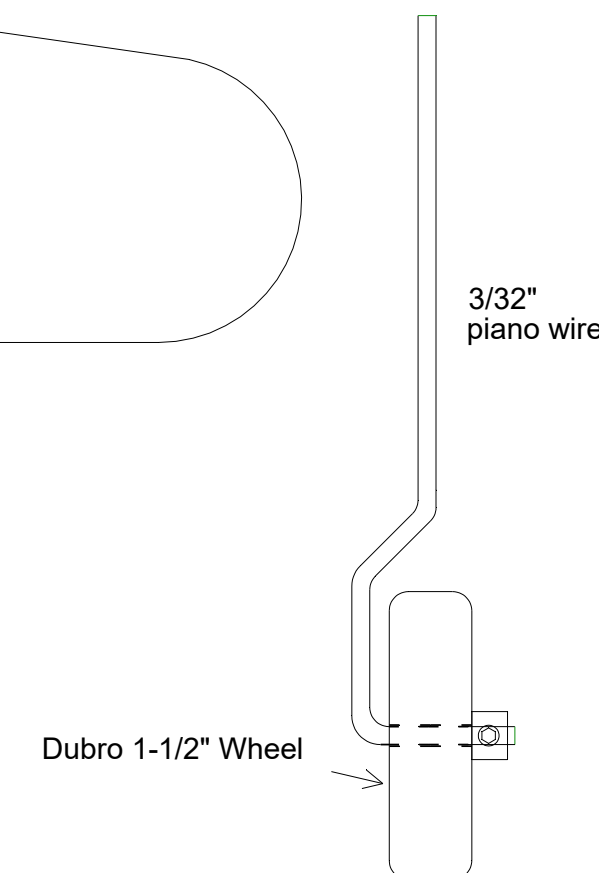
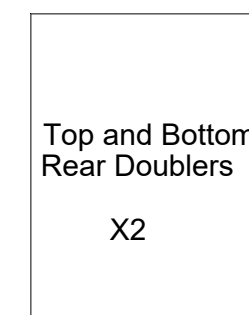
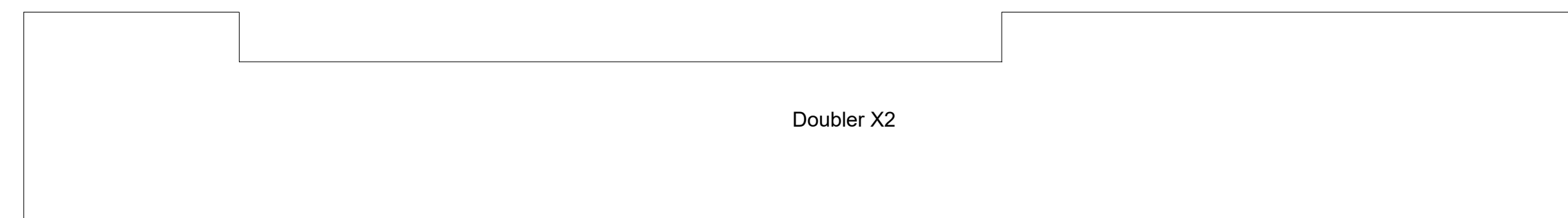
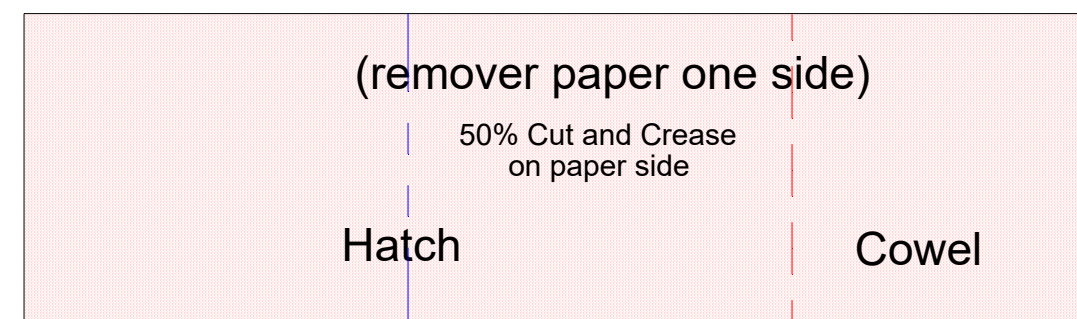

SCOOTER
 3/31/2018 Version 1.0