

1	2	3	4	5	6	6	6	6
----------	----------	----------	----------	----------	----------	----------	----------	----------

--	--	--	--	--	--	--	--	--

--	--	--	--	--	--	--	--	--

1	2	3	4	5	6	6	6	6
----------	----------	----------	----------	----------	----------	----------	----------	----------

--	--	--	--	--	--	--	--	--

1	2	3	4	5	6	6	6	6
----------	----------	----------	----------	----------	----------	----------	----------	----------

--	--	--	--	--	--	--	--	--

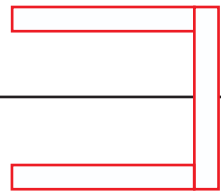

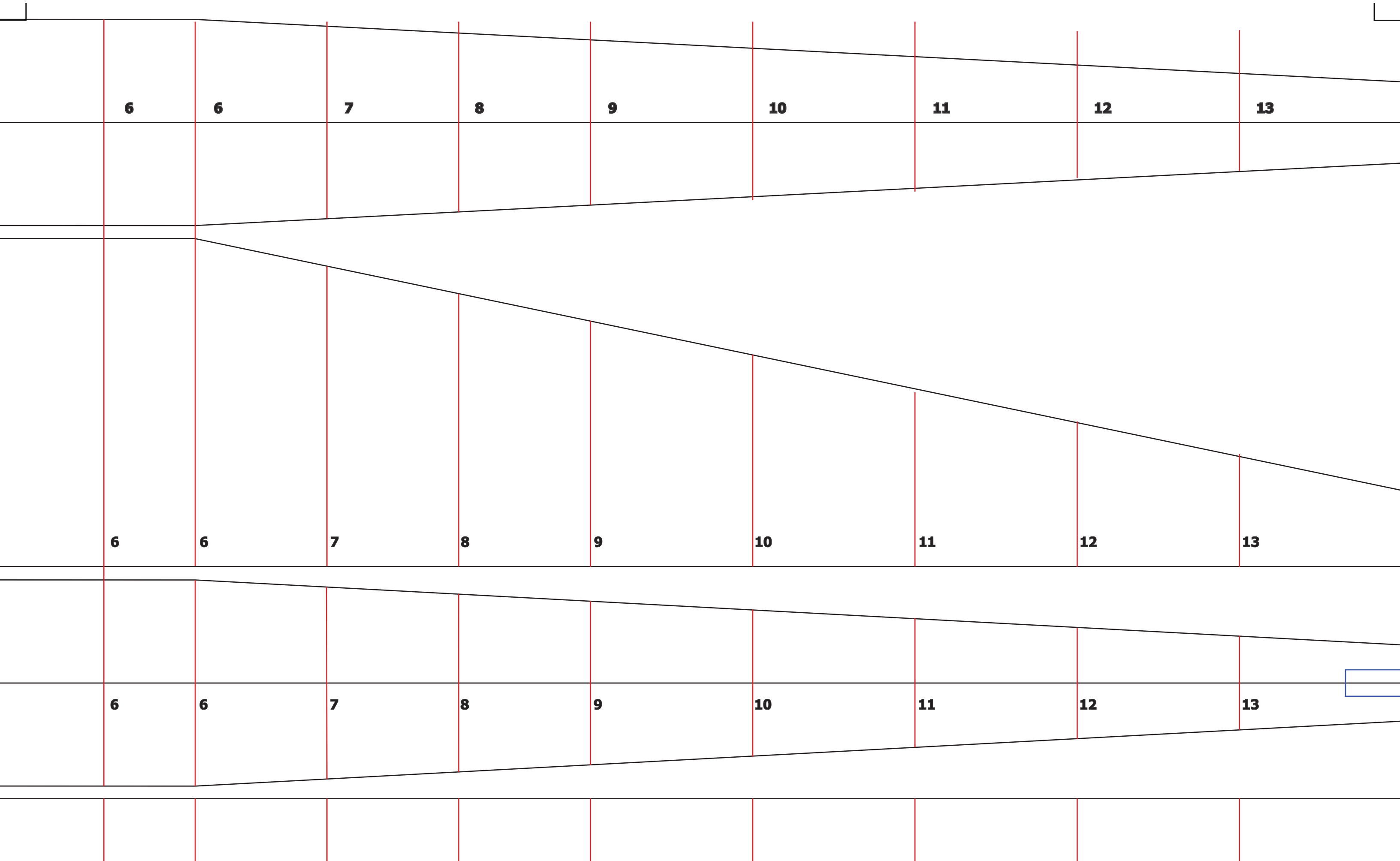

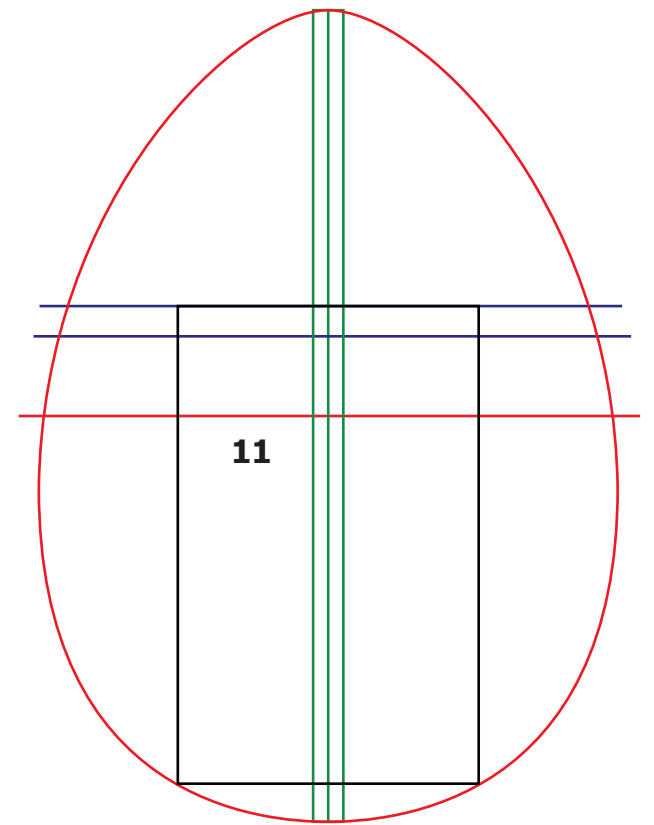
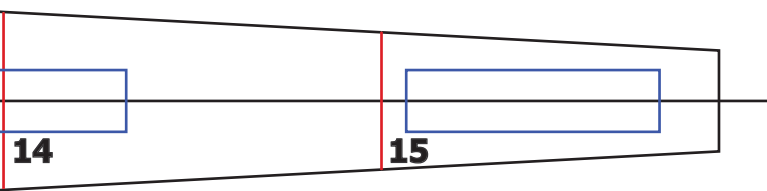
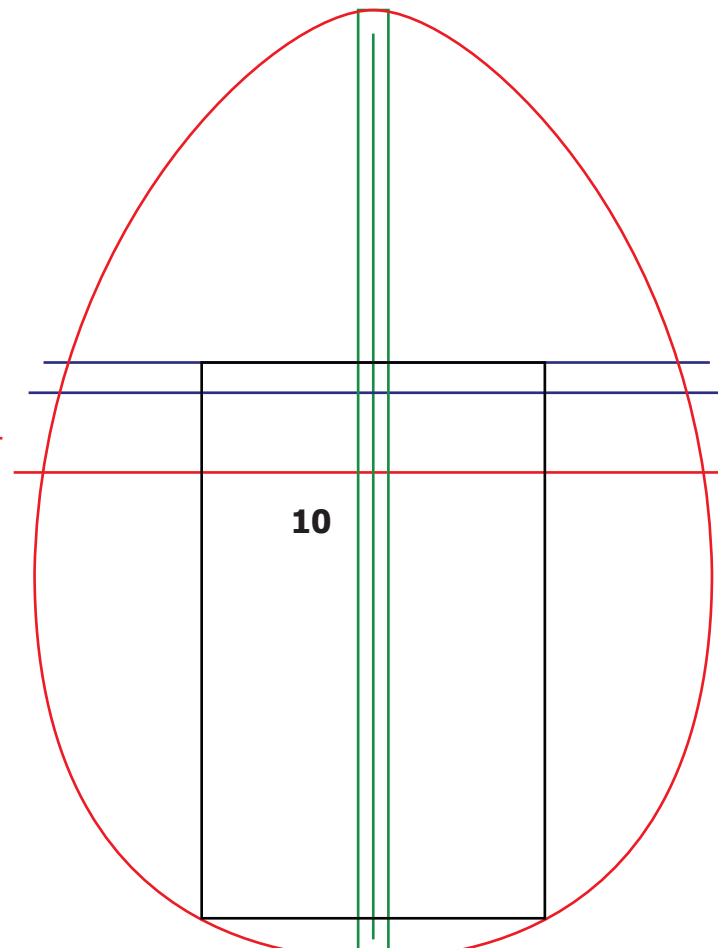
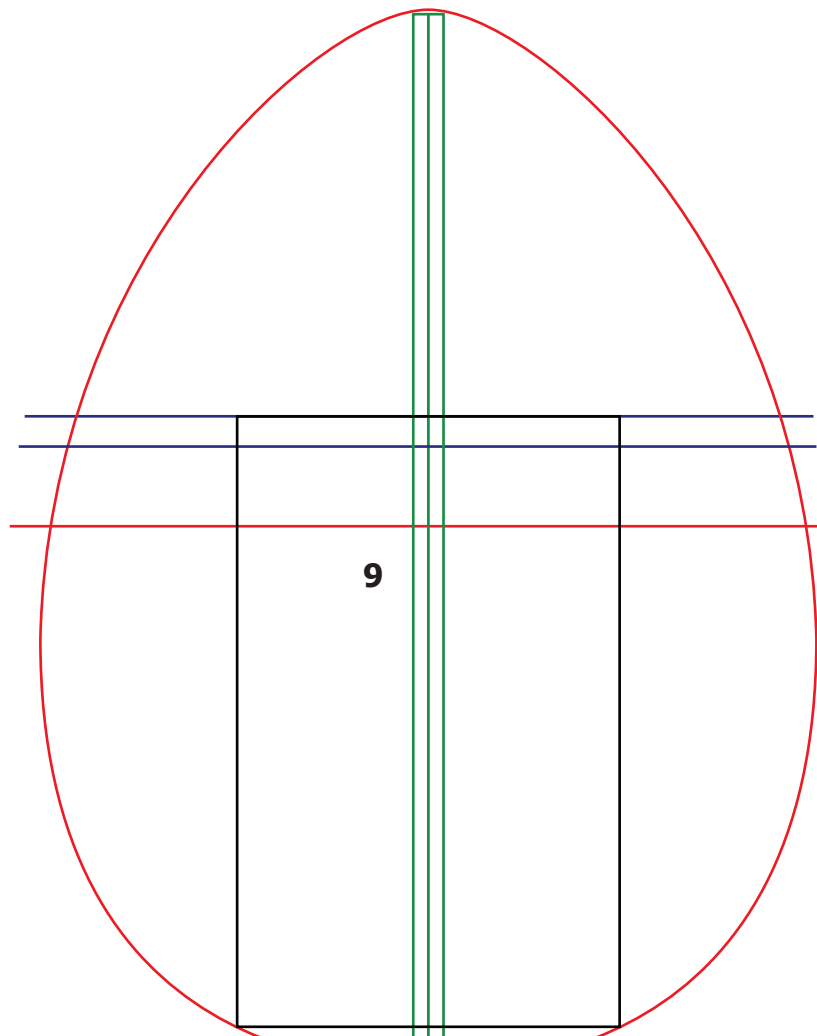
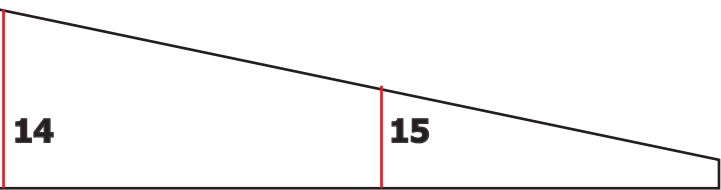
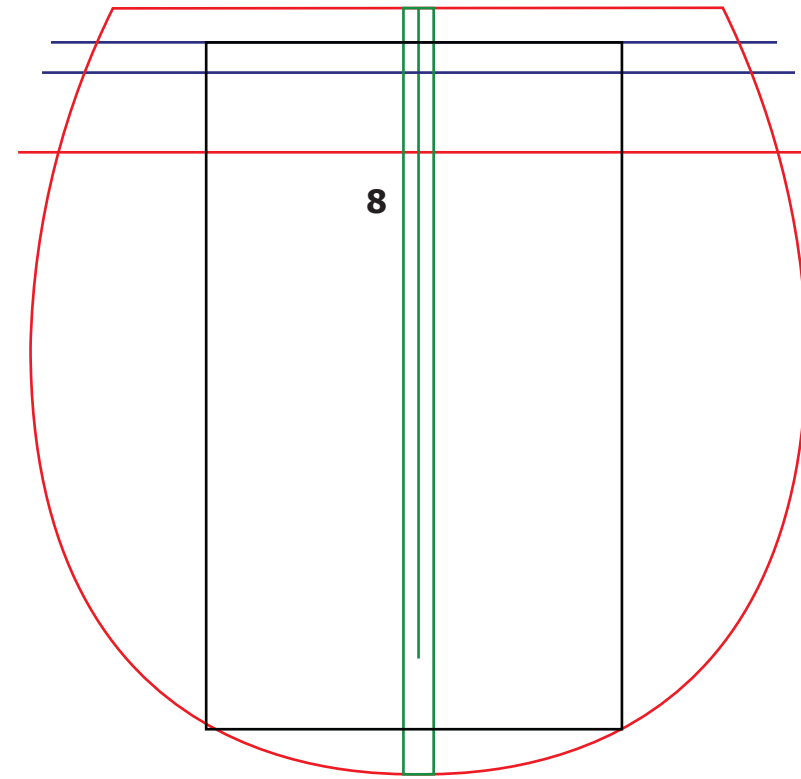
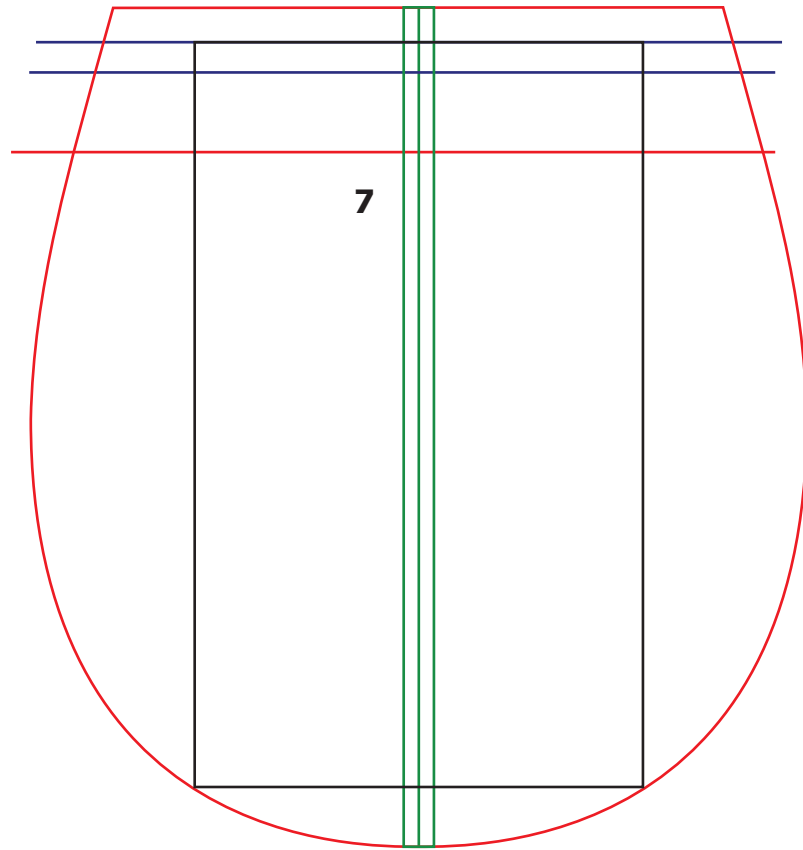
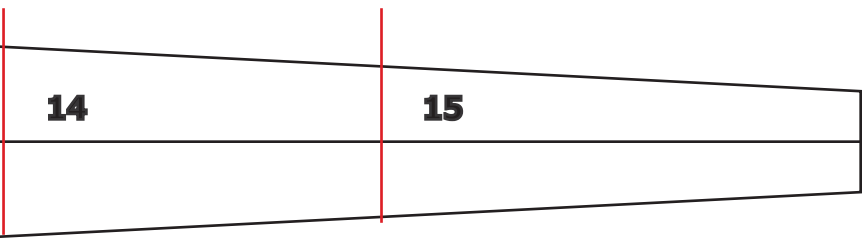

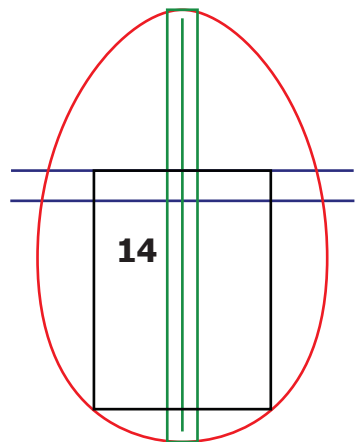
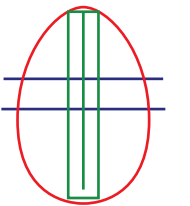
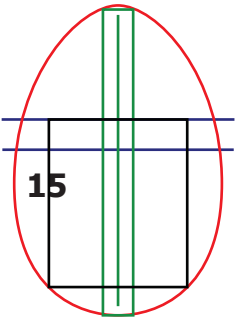
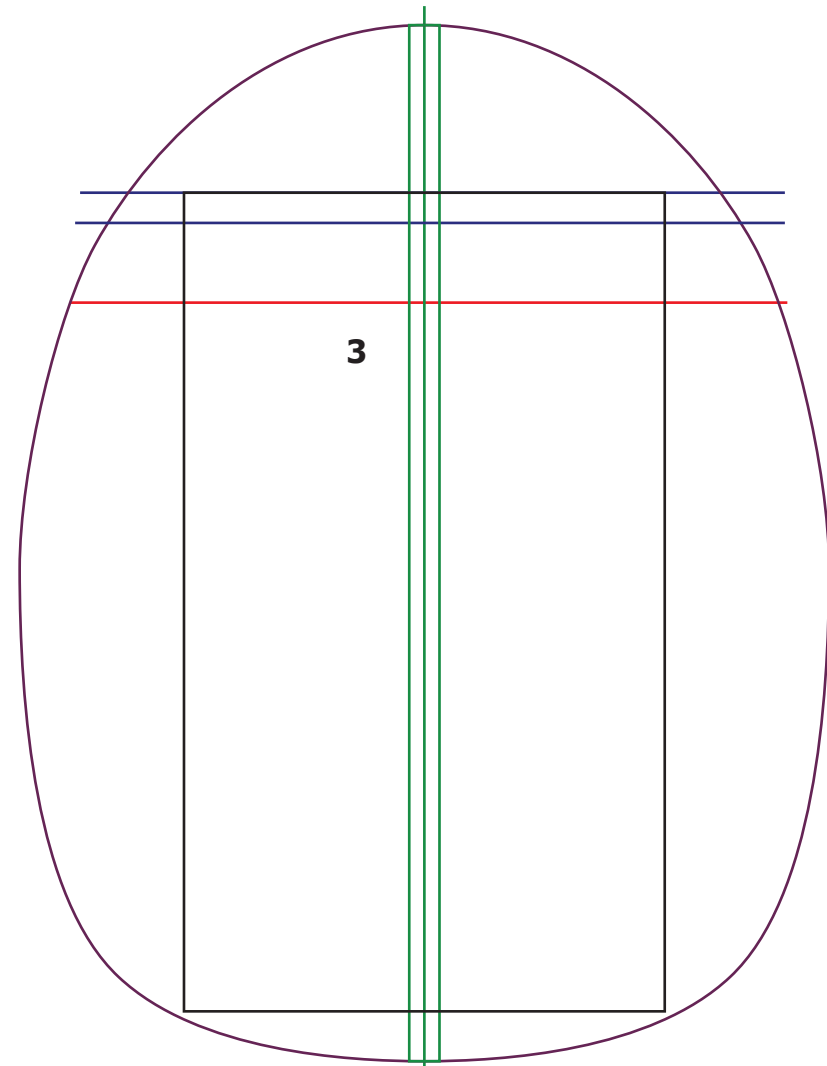
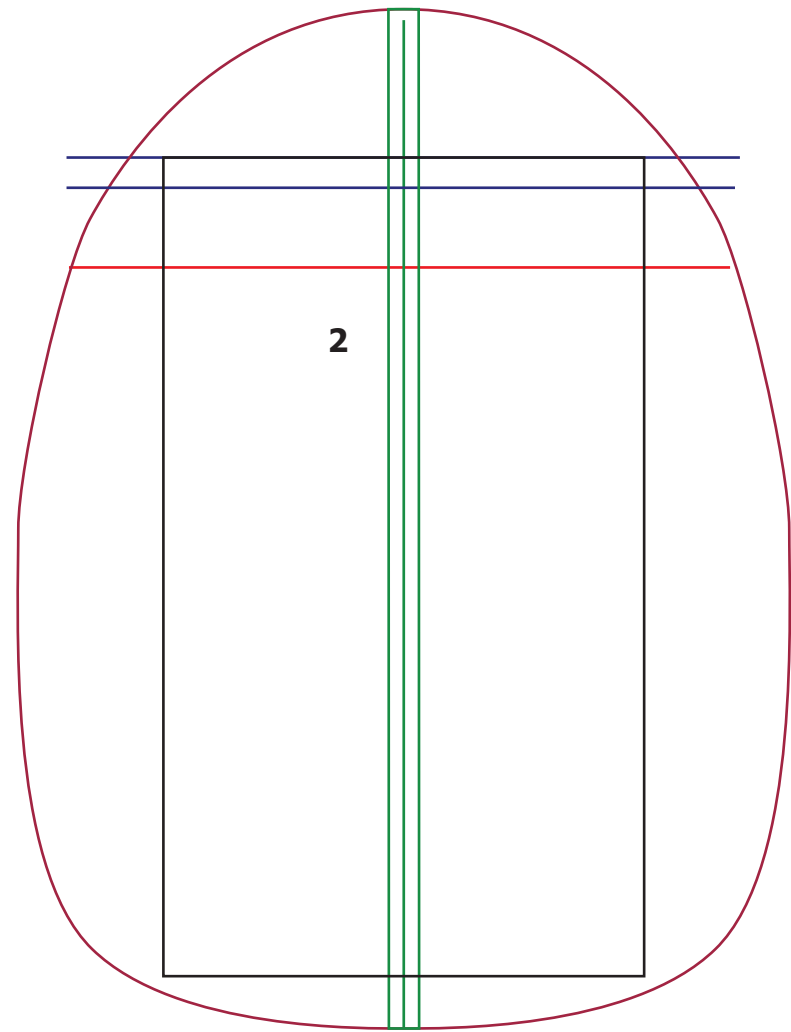
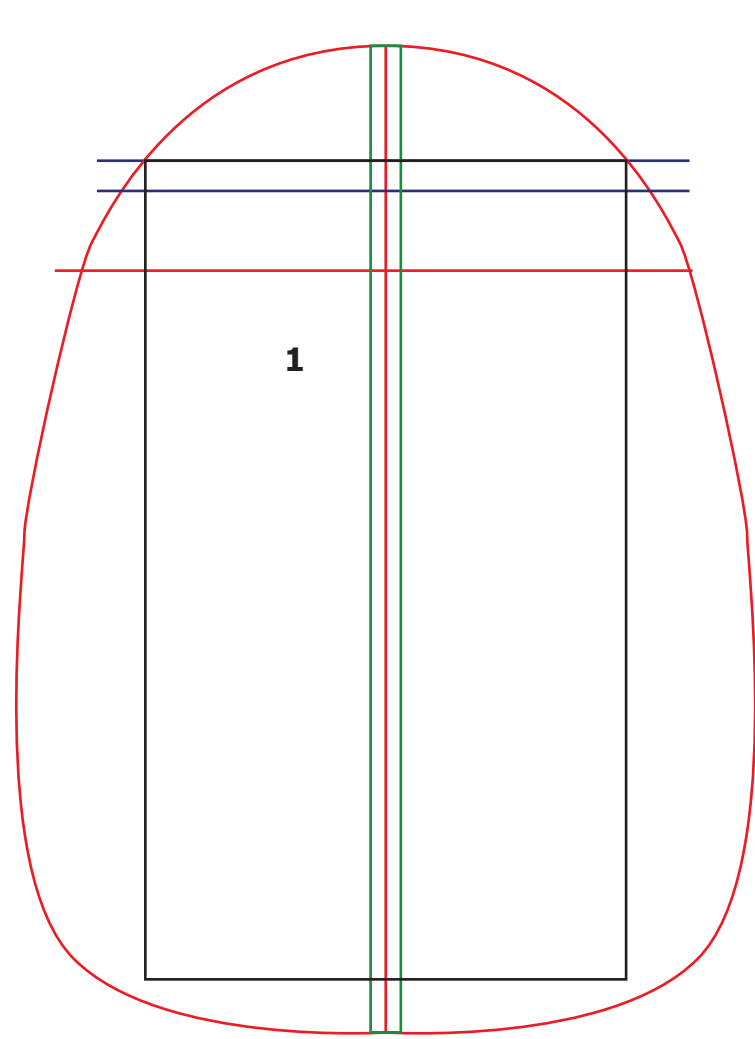
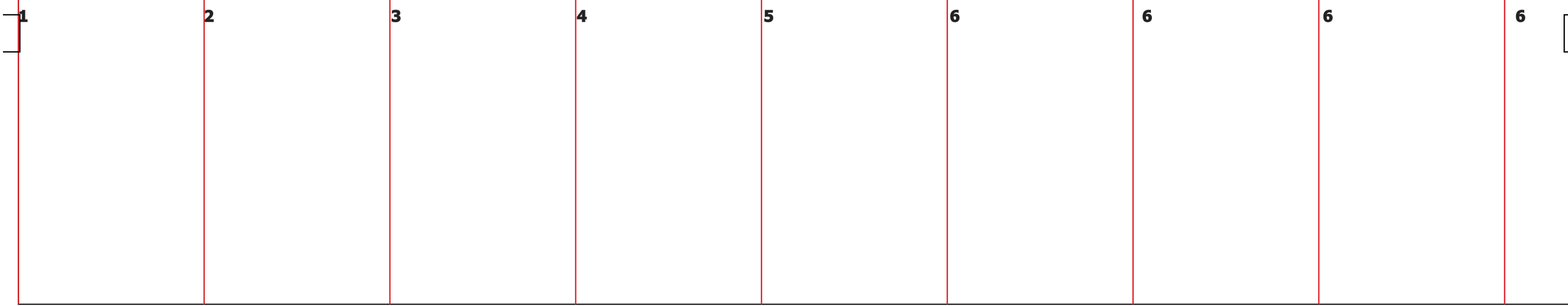

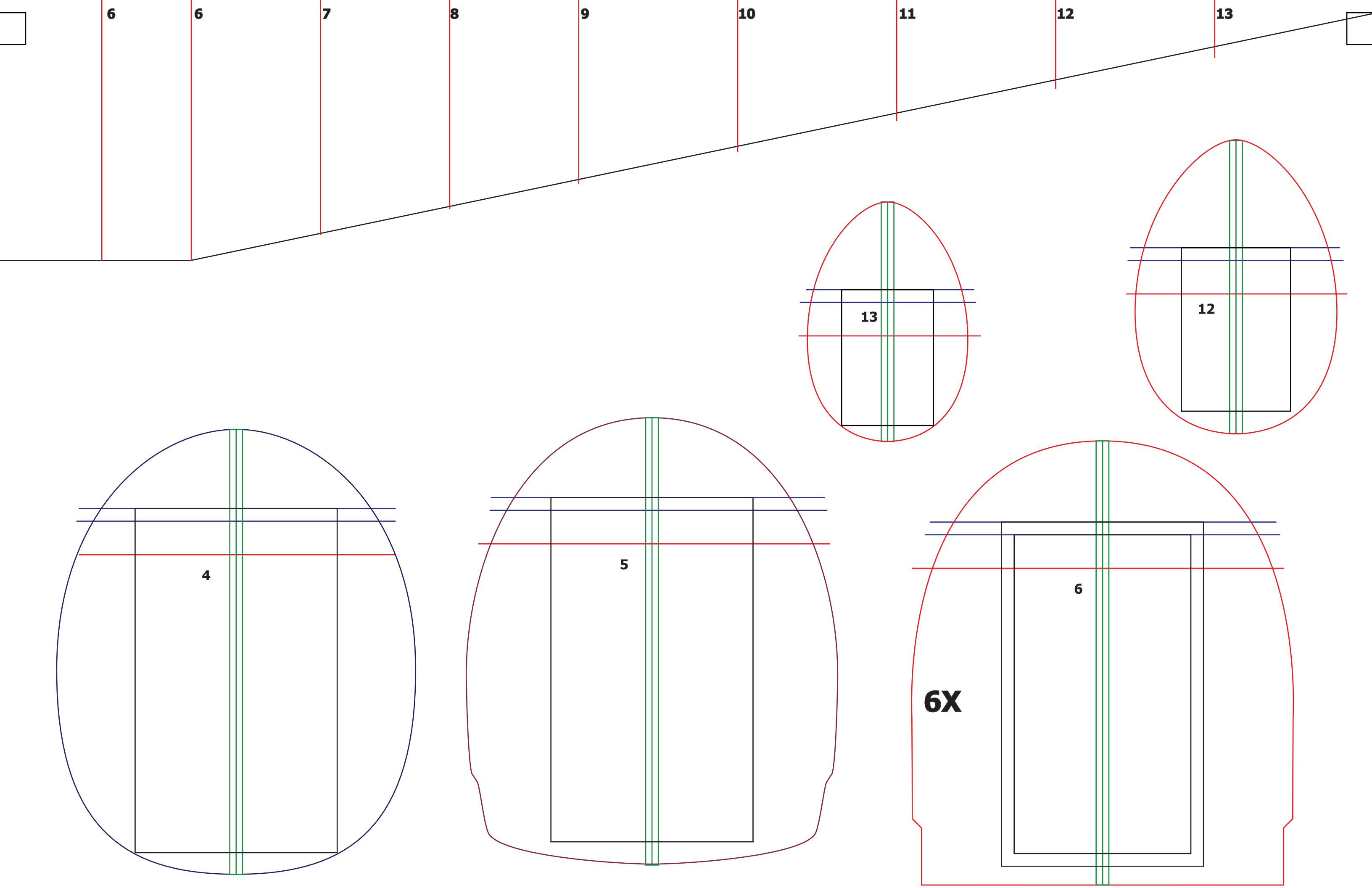

6

6

7

8

9

10

11

12

13

13

12

4

5

6X

6

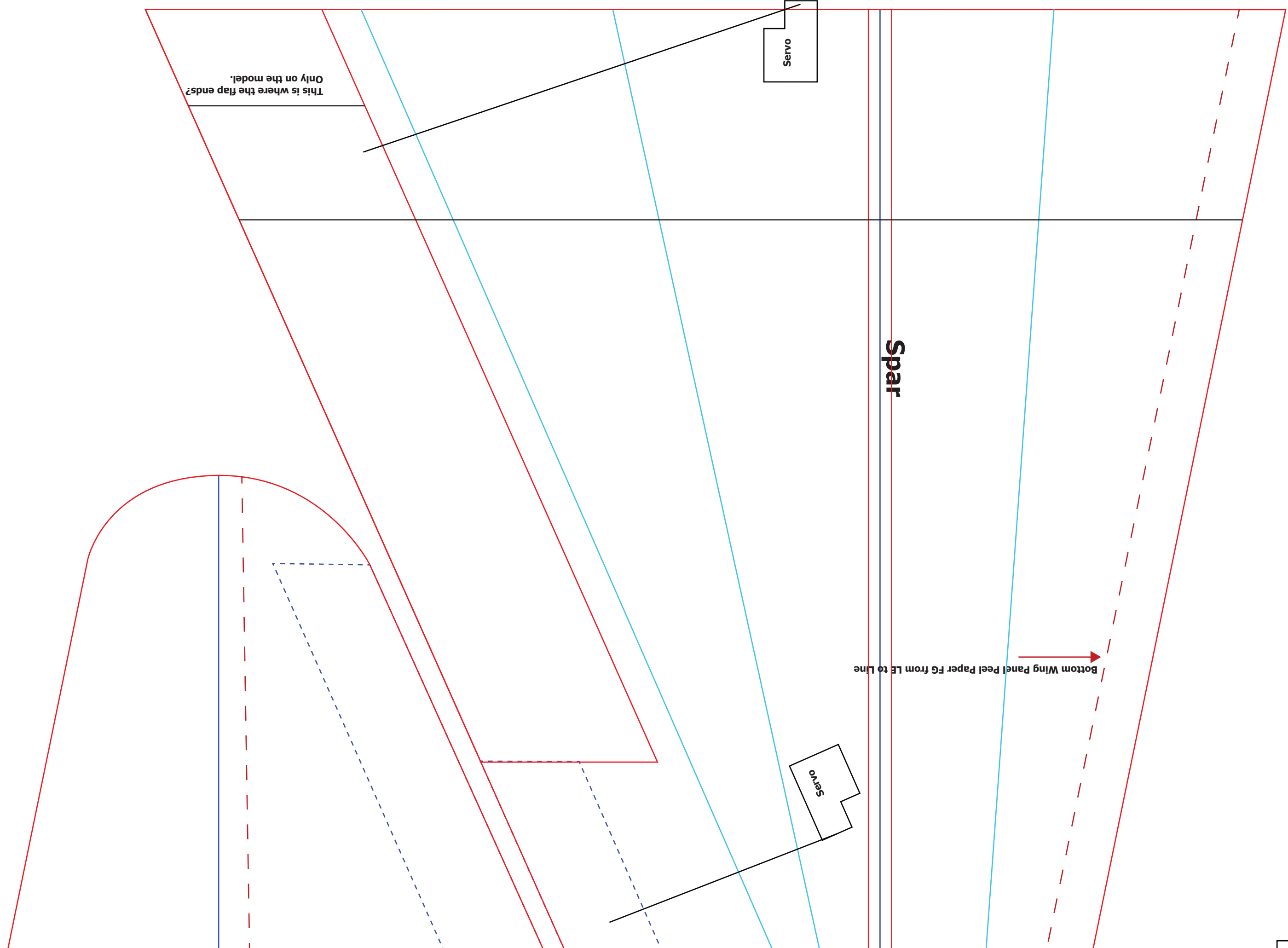

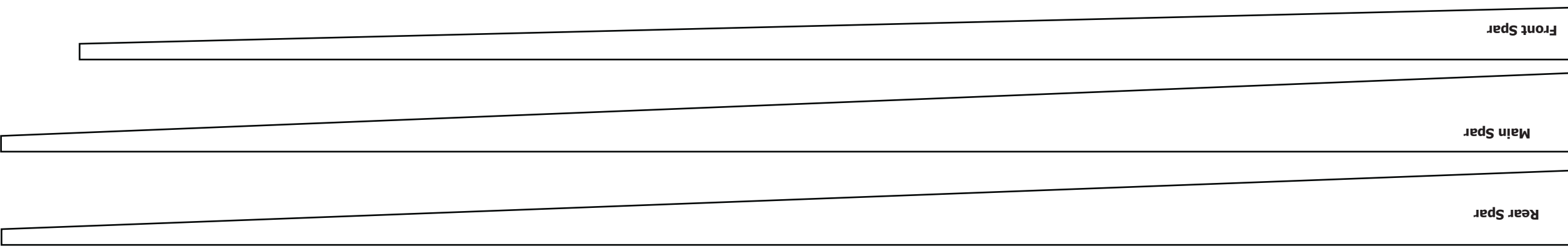
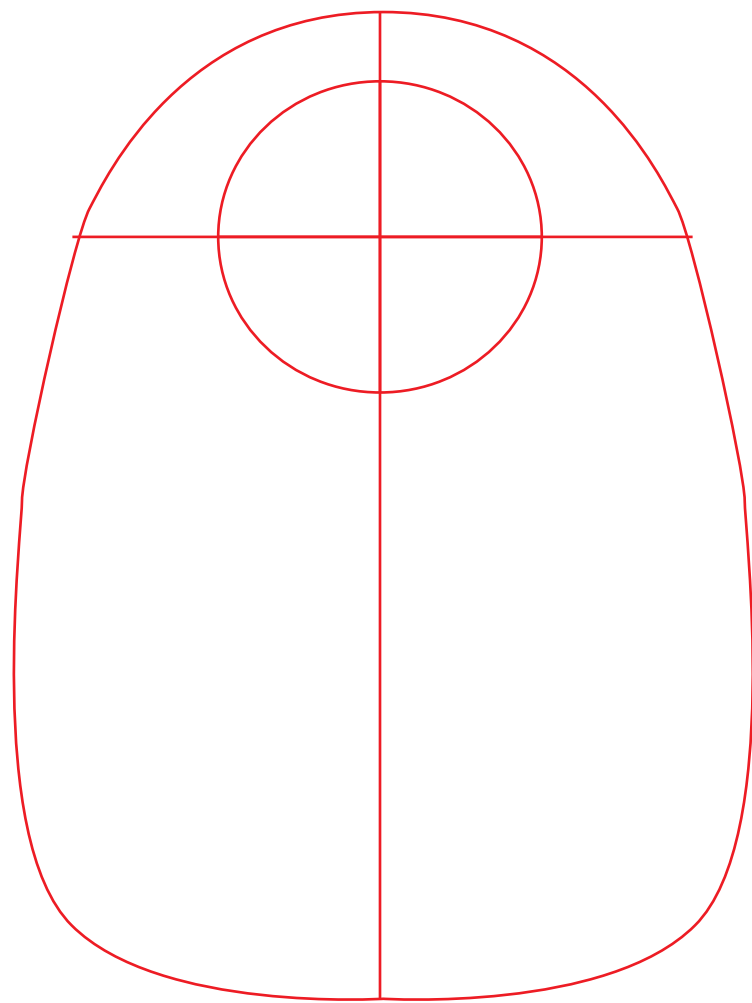

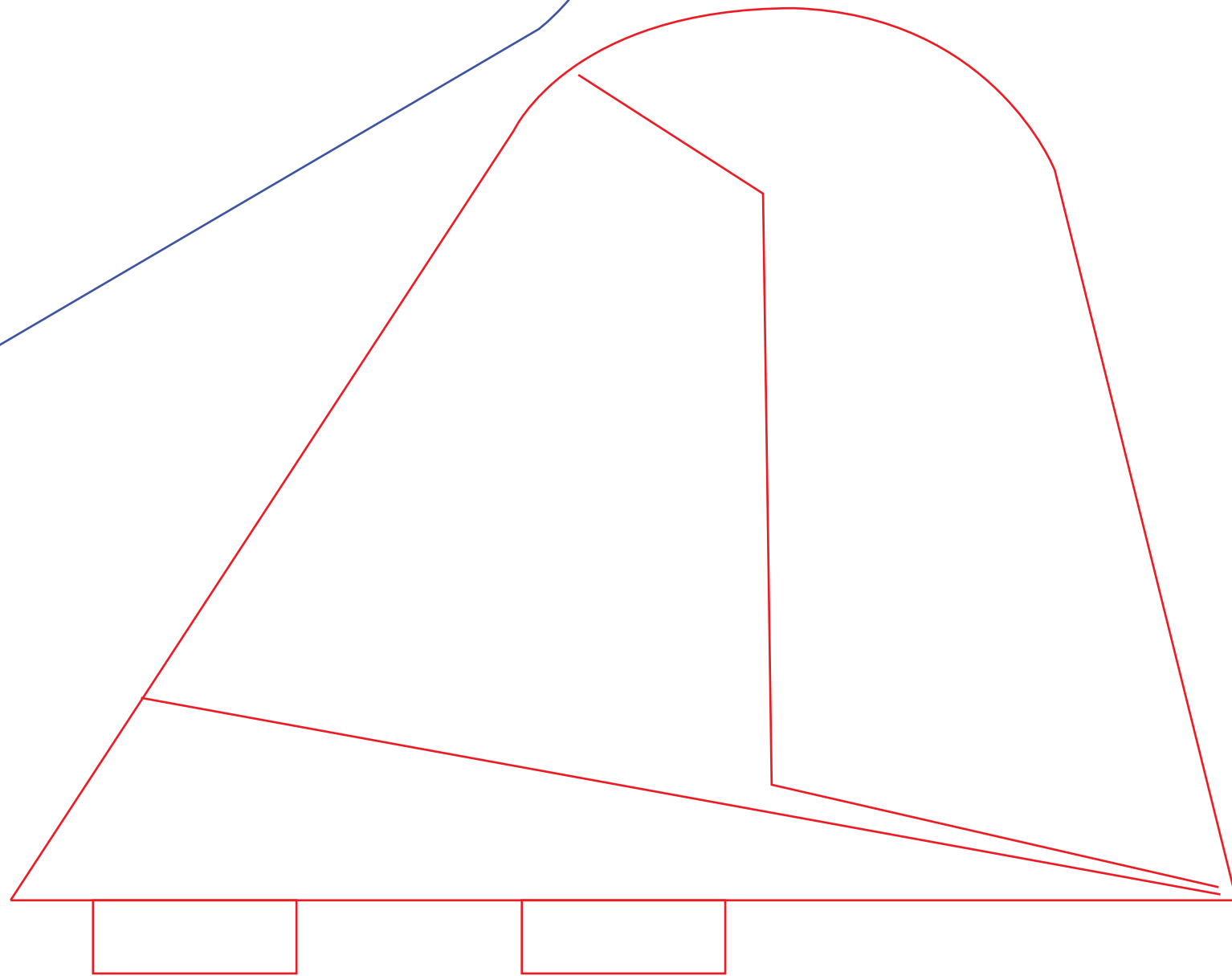
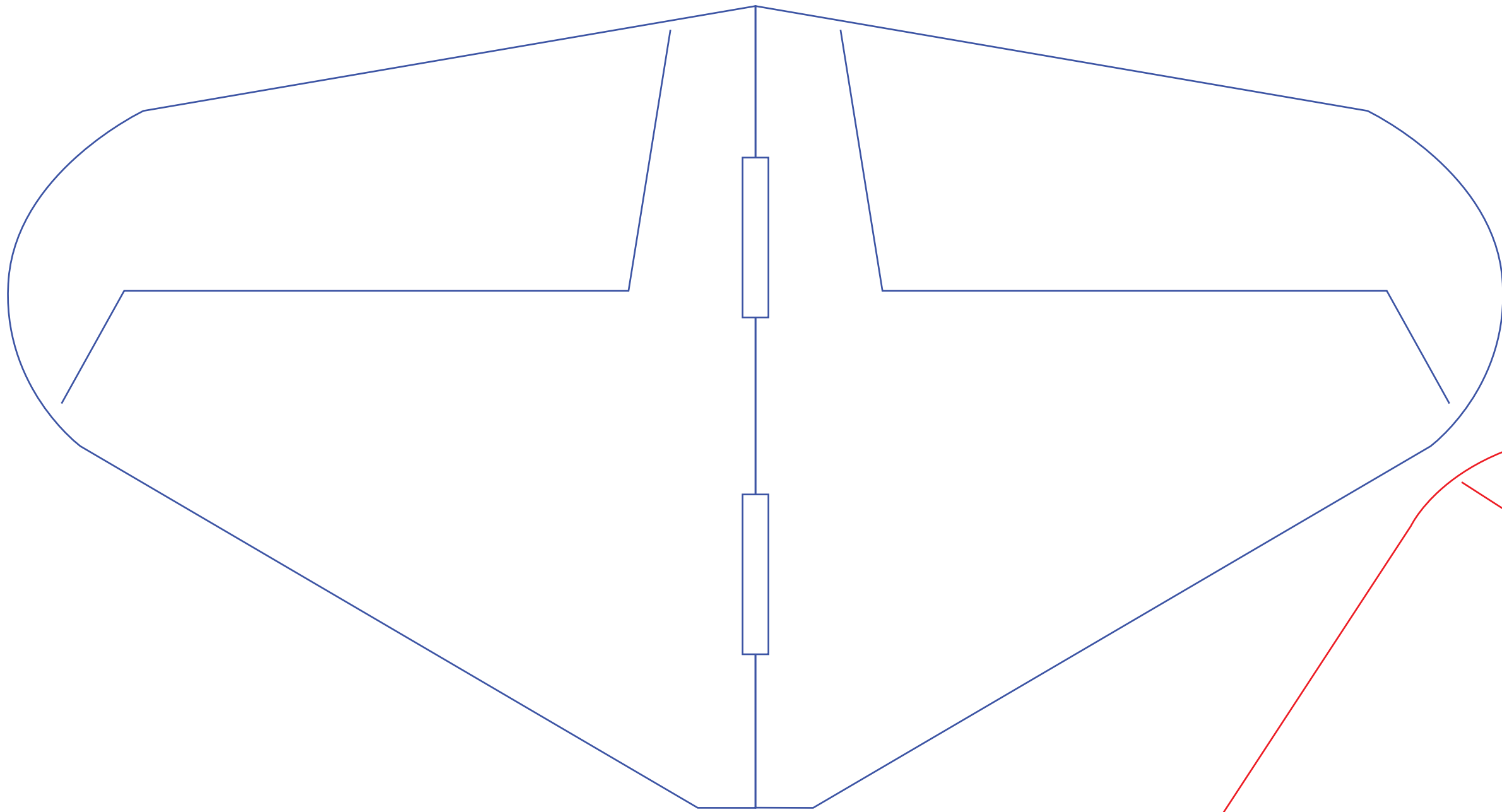

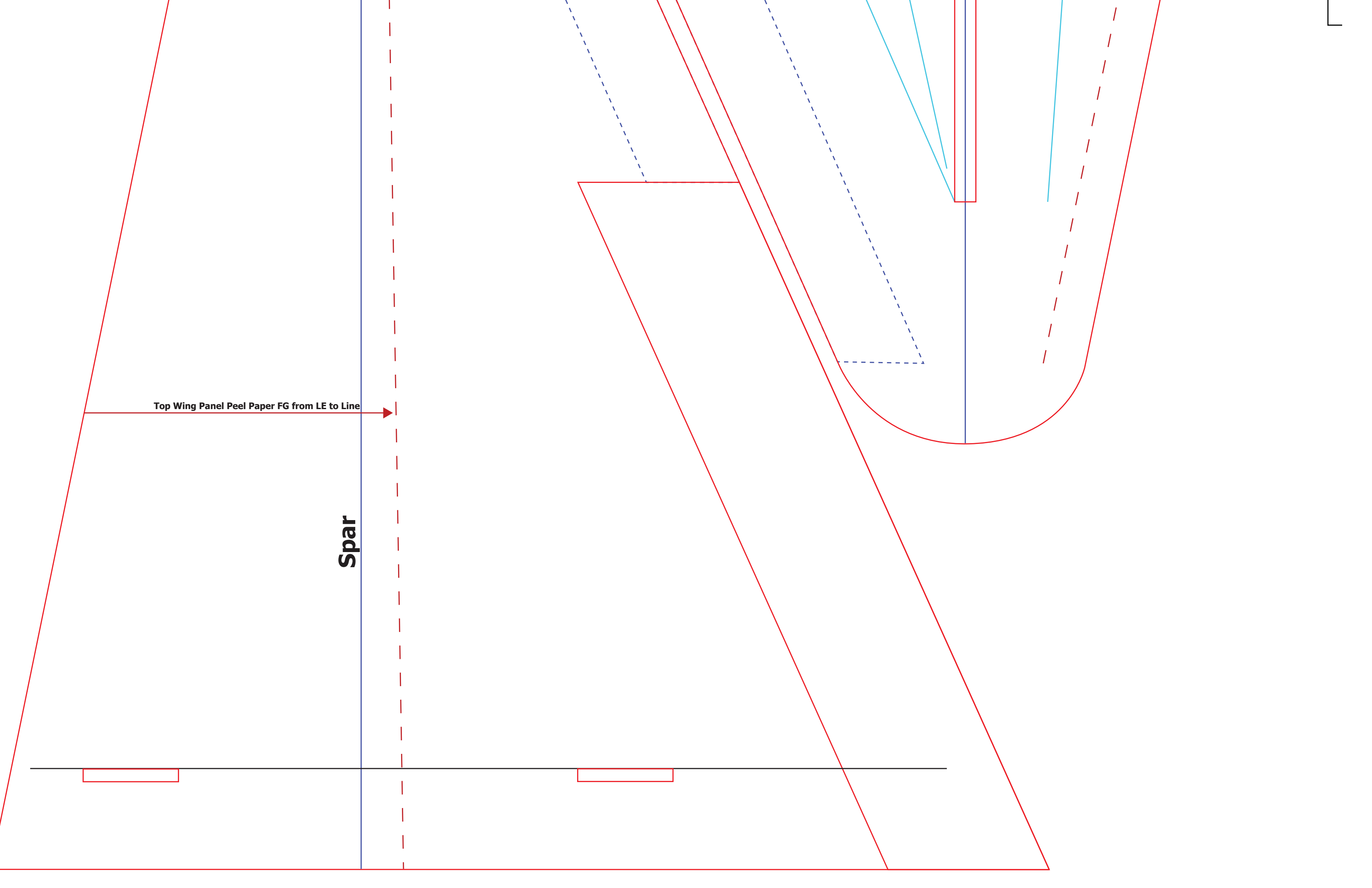

Top Wing Panel Peel Paper FG from LE to Line

Spar